

Automatic Swing Door Operator DFA 127

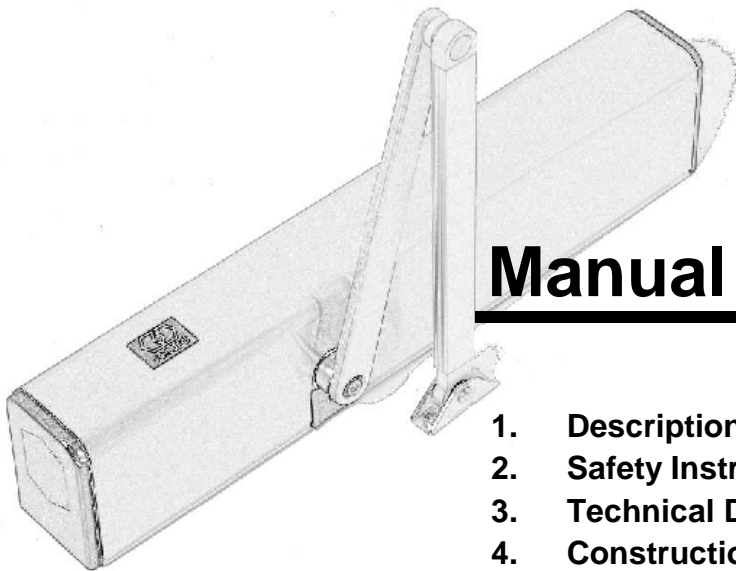

Manual

E

	Page
1. Description of the equipment	2
2. Safety Instruction	3
3. Technical Data	4
4. Construction and Function	5
5. Types of Arms	6
6. Level adaptors for stand arms	7
7. Installation instructions for standard arms	8
8. Installation instructions for slide arms	9
9. Assembly dimension diagrams	10 - 13
10. Adjusting possibilities for arms	14
11. Installation	15 - 18
12. Commissioning	19 - 22
13. Operating instructions	23 - 26
14. Mech. control elements and indicators	27 - 28
15. Configurations	29 - 39
16. Master/Slave applications	40 - 41
17. Status and fault signals BDE-D	42 - 45
18. Maintenance instructions	46
19. Control references for new assembly	47 - 48
20. Abbreviations	49
21. Cable layout	50 - 51
22. Wiring diagram	52 - 54

agtatec ltd

Allmendstrasse 24

CH-8320 Fehraltorf

Phone +41 44 954 91 91

Fax +41 44 954 92 00



1 Description of the equipment

The record DFA 127 (Full Power) is a compact, self-monitoring, microprocessor-controlled swing door operator (abbreviated to DFA). With its many special and additional functions, it is suitable for a very wide application spectrum. The path of every door movement is controlled by the microprocessor, which evaluates the current door position, the door speed and the final position at every instant and precisely calculates the optimum motion. This makes the familiar end-stops, jerky braking actions, creep speeds etc. unnecessary. Depending on the door width, the corresponding spring range must be selected in the range of EN 4 to EN 6 (according to European Norm EN 1154). Safety is also additionally increased by the use of a redundant force limitation.

Low energy drive (Low Energy)

In the parameterisation of the Low Energy door type, the DFA acts as an automatic low energy operator. The opening and closing speeds are limited and the operator is more sensitive in case of a collision. The closing action takes place using spring force and reduced kinetic energy. To prevent unintentional or malicious modifications to the program, user access to the parameters is blocked. The set values for the permitted speeds are indicated in DIN 18650-2. They are calculated depending on the weight of the door leaf and the width of the door.

1.1 Types of arms, including accessories

The power transmission from the motorisation unit to the door leaf is carried out by a set of arms. Depending on the installation situation, the optimal solution can be selected from two different types of arms (standard or slide arm). Standard arms are available in different lengths for various lintel depths. By using optional extension pieces, so-called adaptors, different lintel heights can be compensated.

1.2 Accessories and special applications for the DFA 127

5 operational modes can be remotely selected with the external BDE-D, which is available as a flush-mounted or surface-mounted model.

Master / Slave

In the Master / Slave operation, two DFA 127 can be sequentially controlled without additional mechanical door locking systems.

Not suitable for fire protection doors!

Extended operator casing

The installation of additional sensor devices is possible using an extended operator casing.

Flexible cable connection

With the flexible cable connection, the wiring of DFAs that are mounted on the moving door leaf can be carried out in an elegant manner.

5 operational modes can be remotely selected with the external BDE-D, which is available as a flush-mounted or surface-mounted model.

2 Safety Instructions

The DFA 127 has been constructed to the latest state-of-the-art and the recognised technical safety regulations, including, for example, limitation of forces and speeds. Danger can arise for users, however, if not used as intended.



Installation, maintenance and repairs on the DFA 127 may only be carried out by qualified and authorised personnel.

2.1 Use as intended

The DFA 127 swing door operator is designed exclusively for the normal operation of swing doors in dry rooms, and must be installed within or inside buildings.

Any different application or use extending beyond this purpose is not considered to be use for the intended purpose. The manufacturer declines all responsibility for any damage resulting from this; the operator alone will bear the associated risk.

Use for the intended purpose also includes observation of the operating conditions specified by the manufacturer, including the use and adjustment of the correct type of arms, in addition to regular maintenance and repair.

Unauthorised modifications to the automatic door operator will exclude any liability of the manufacturer for resulting damage.

2.2 General safety and accident-prevention regulations



In general, no safety devices (sensors) may be dismantled or put out of service.



The safety devices (sensors) are switched off during the learning cycle (which must only be performed by trained personnel)! Before initiating the learning cycle, it must therefore be ensured that no persons or objects are situated in the danger zone of the moving door leaves during operation in order to avoid injury or damage!



No objects must be placed in the opening zone / path of the swing door to avoid crushing and shearing points!
The safeguard against crushing and shearing strains at the side edge must be provided by the manufacturer.

3 Technical Data

Dimensions:	Operator 600 x 85 x 124 mm (w x h x d)
Operating voltage:	230V~
Power consumption:	Standby 13 W, rated power 67 W
Max. torque:	50 Nm
Opening angle:	adjustable from 70° to 115°
Time delay:	adjustable from 0 to 20 seconds
Opening speed:	adjustable from 3 to 20 seconds
Closing speed:	adjustable from 5 to 20 seconds
Noise emission	-18 dB

Environment conditions

Temperature range:	-15 to + 50°C
Humidity range:	up to 85% relative humidity, non condensing

3.1 Permissible door leaf weights and door widths

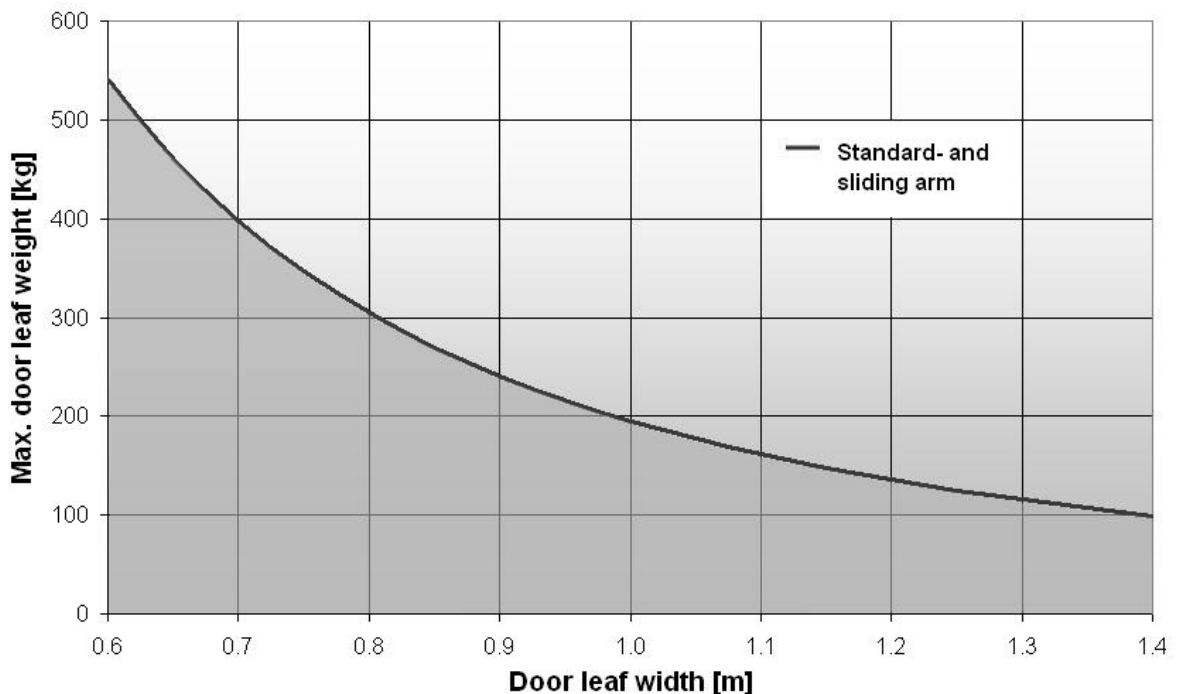

Recommended door leaf width for door closer classes



The curves are calculated using the following formula:

$$J = 1/3 \cdot m \cdot b^2$$

Standard arms	: J max. 65 kgm ²	Key :	J = mass moment of inertia [kgm ²]
Slide arms	: J max. 65 kgm ²		m = door leaf weight [kg]
			b = door leaf width [m]

4 Construction and Function

4.1 Construction

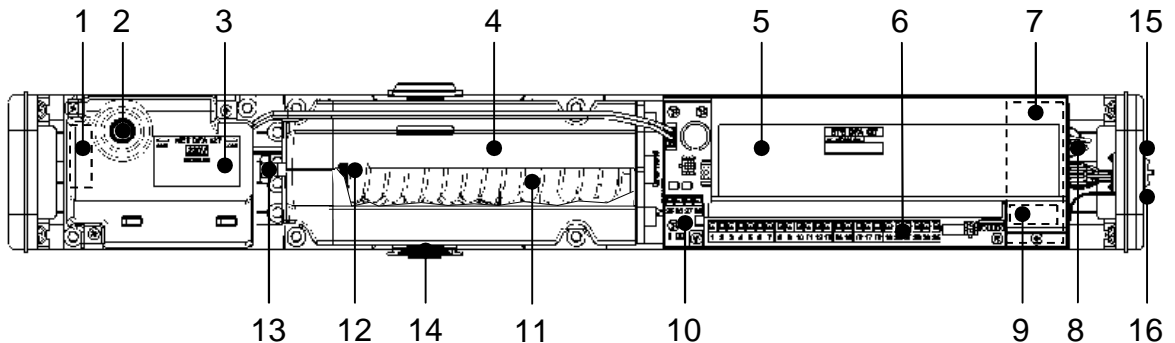

Key to illustration:

- | | |
|------------------------------|---|
| 1 Mains connection terminals | 9 Slide switch S1 (rotation direction) |
| 2 Fine-wire fuse | 10 Multifunctional switch MF on STG |
| 3 NET power supply | 11 Closing spring |
| 4 ATM drive unit | 12 Vision panel, adjust. spring tension |
| 5 STG control unit | 13 Adjusting screw for spring tension |
| 6 STG connection terminals | 14 Connectors for arms (both sides) |
| 7 Motor print MOT | 15 Standard switch BDI |
| 8 ATE drive unit terminals | 16 Status signal and Reset button |

4.2 Functions

The record DFA 127 has been designed to close without electrical power. It can be easily opened by hand and closes using the energy stored in the spring, with the motion damped by the motor acting as a generator.

If the door operator is connected to the mains power, the opening and closing movements will be assisted by the motor.

The following functions are provided exclusively for the safety of the user:

Collision detection: If the door strikes an obstacle while opening, it stops immediately and stores the position of the impact. During the time delay, the drive briefly tries to reach the open position. Once the time delay has expired, the door closes, and, when next opened, the door passes the impact position very carefully in slow mode. This prevents a further violent impact.

Reversing: If the door strikes an obstacle when closing, it is reopened immediately.

5 Types of arms

5.1 Standard arm

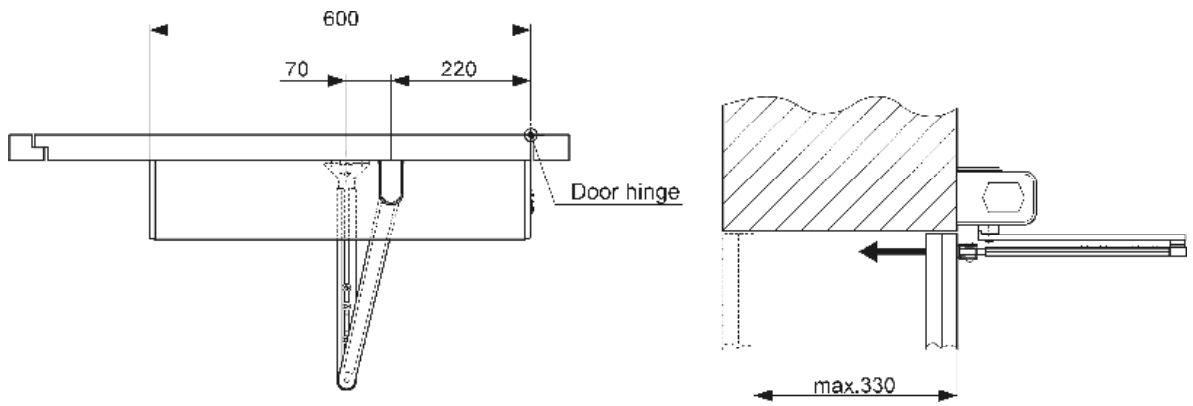

5.2 Slide arm pulling

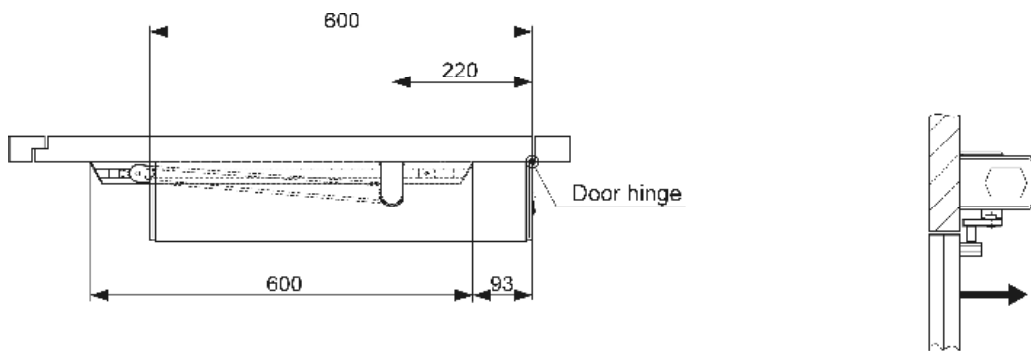

5.3 Slide arm pushing

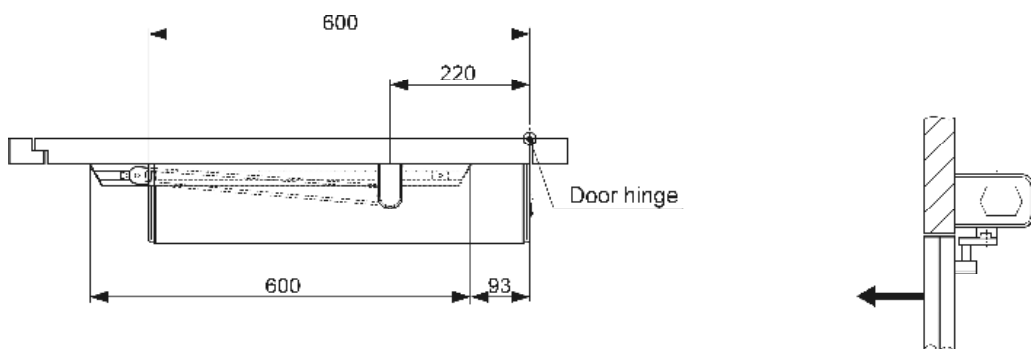

6 Lever adapters for arms

The lever adapters are the joining elements between the operator drive shaft and the arm lever. They also serve as extension pieces to compensate height differences between the operator and the connector to the arms. A lever adapter 20 is included in each delivery.

6.1 Standard arm

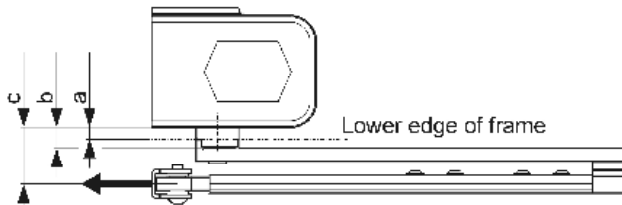

6.2 Slide arms pulling and pushing

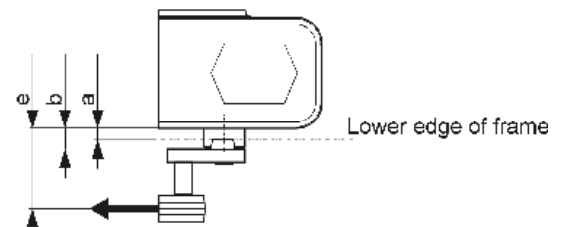
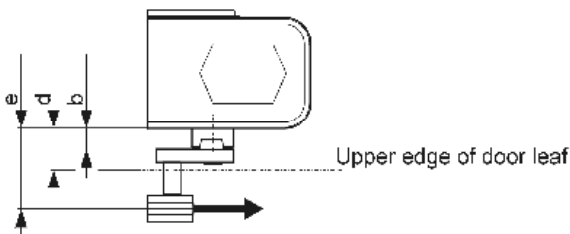

Type of arms	Lever adapter 20	Lever adapter 50	Lever adapter 65	Lever adapter 80
(dimensions in mm*)	127.808.211	127.808.212	127.808.218	127.808.213
Standard arms				
A	8	38	53	68
B	15	45	60	75
c (= ,D')	42.5	72.5	87.5	102.5
Slide arms pulling				
B	15	45	60	75
d (= ,D')	32	62	77	92
E	60	90	105	120
Slide arms pushing				
a	8	38	53	68
b	15	45	60	75
e (= ,D')	60	90	105	120

* The measurements indicated refer to the lower edge of the operator. If the measurement is taken from the lower edge of the chassis, + 1.5 mm must be added

7 Installation plan for standard arms

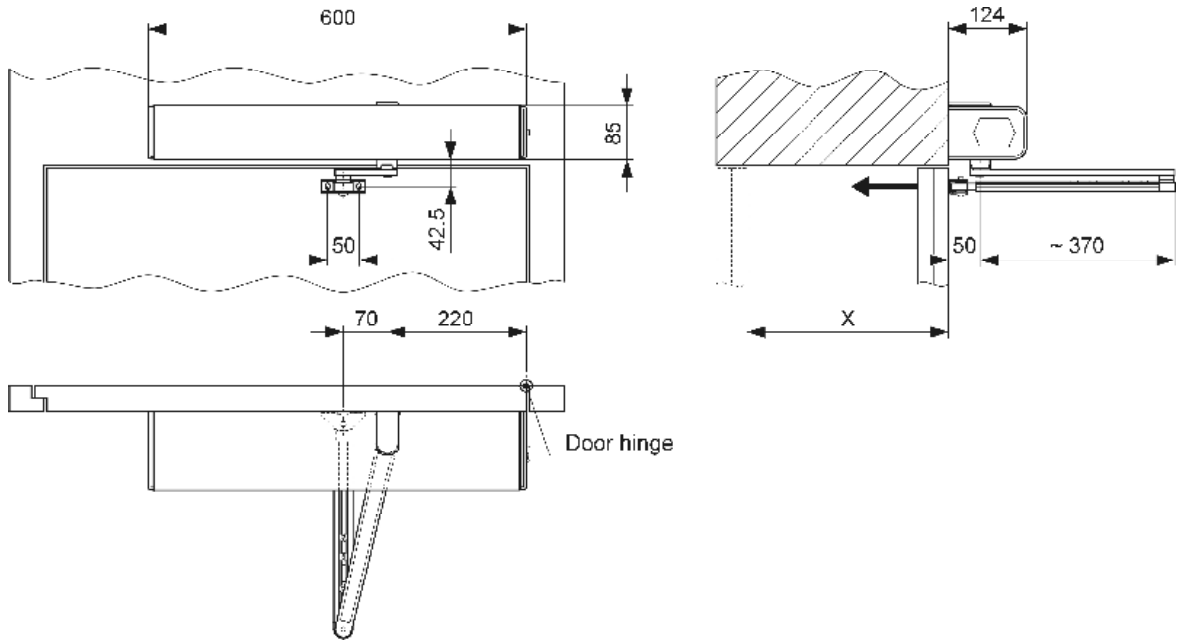

Standard arm	Lintel dimension X (in mm)	Article number
SG 1	0...120	127.808.184
SG 2	100...220	127.808.215
SG 3	210...330	127.808.216

7.1 Chassis

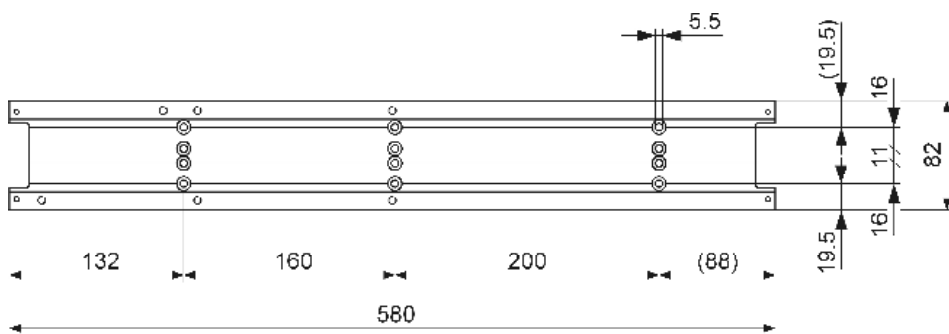

8 Installation plan for slide arms

8.1 Slide arm pulling

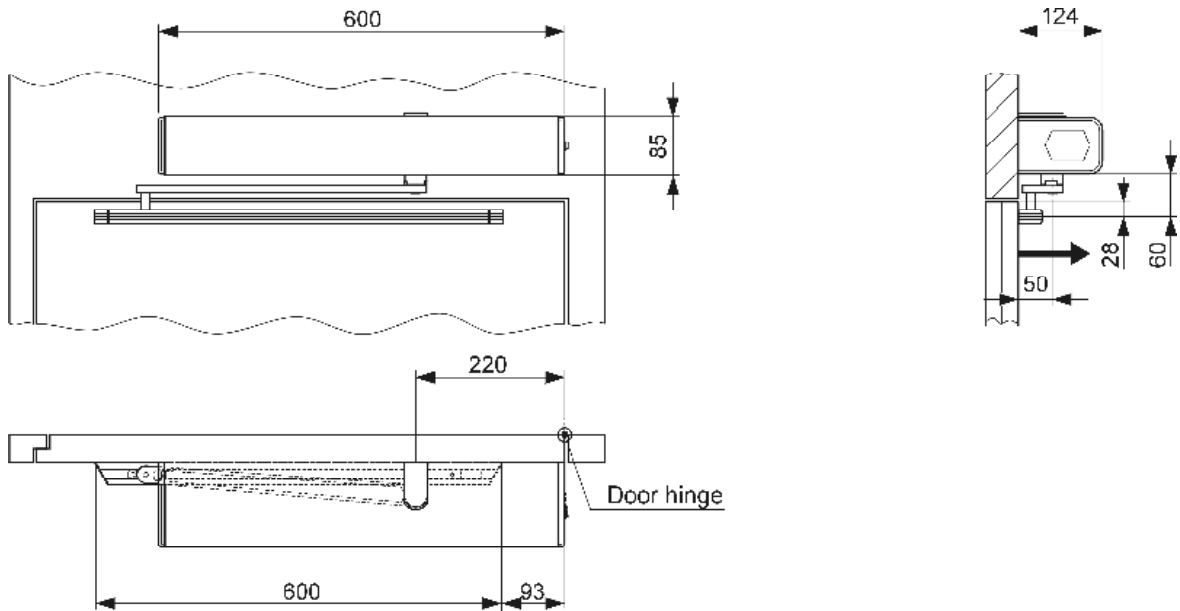

8.2 Slide arm pushing

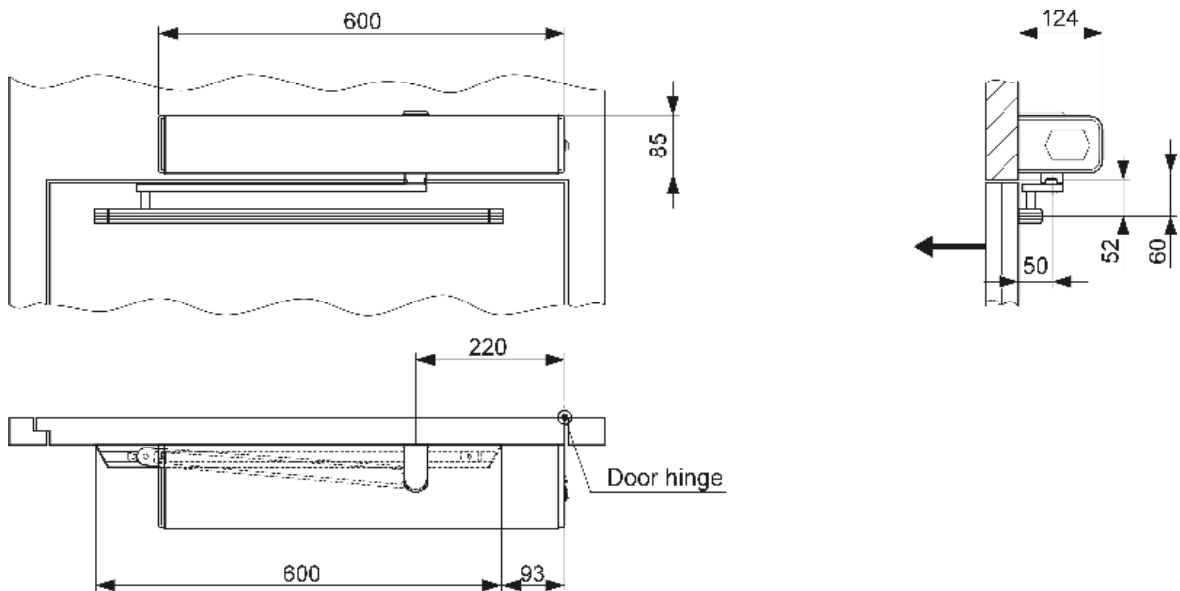

Standard arm	Lintel dimension X (in mm)	Article number
GG	+/- 10	127.808.183

9 Assembly dimension diagrams

9.1 Dimension diagram 1 for standard arms

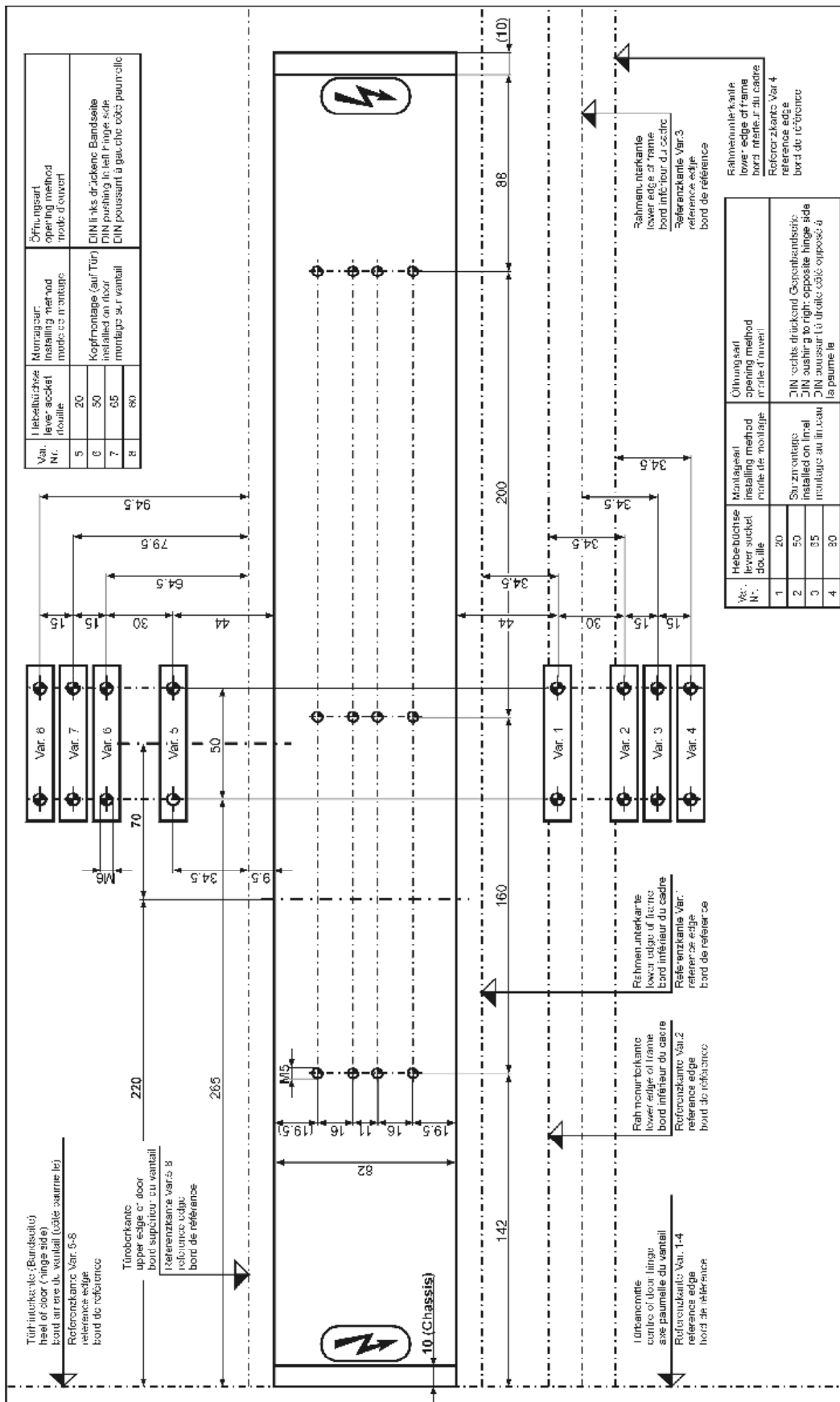

10 Adjustment possibilities for arms

10.1 Angle adjustment

The serration of the level adaptor allows a step-by-step adjustment of the angle (6°).

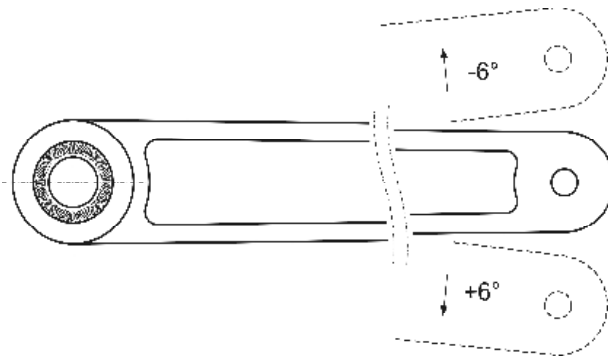

CAUTION: The connecting screw between the operator and the lever arm must be tightened firmly, and must be checked constantly.

It is recommended to tighten the connecting screw after the final adjustment.

9.2 Length adjustment

The length of the standard arms can be adjusted in a certain range for optimal fit to the lintel depth. The two marked screws thereby have to be loosened with a **5 mm** Allen key. The profile must be relocated to set the lever to an angle of about 90° to the door leaf.

CAUTION: All screwed connections must be firmly tightened!

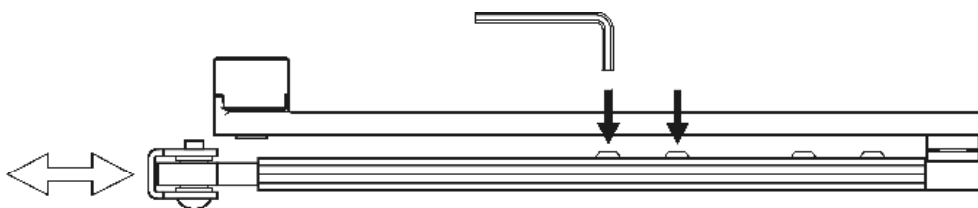

To lower the initial load, the lever arm can be adjusted at an angle of 6° in the counter rotation sense of the opening.

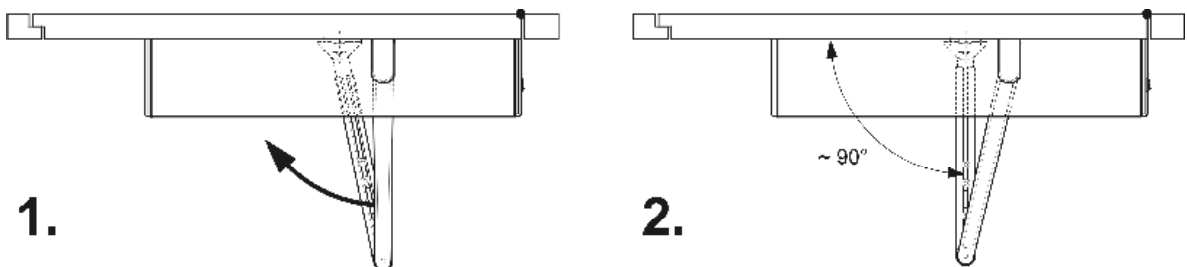

11 Installation and commissioning

11.1 Checking the installation site

- Does the door leaf move easily over its entire swing range?
- Does the door leaf drop cleanly into the lock?
- Have all damping devices been removed (not simply reset)?
- Is the base on which the DFA 127 is to be mounted sufficiently stable? The chassis must lie as flat as possible. Coarse unevenness must be cleared or the bearing area must be made more powerful or be strengthened by means of additional plates.

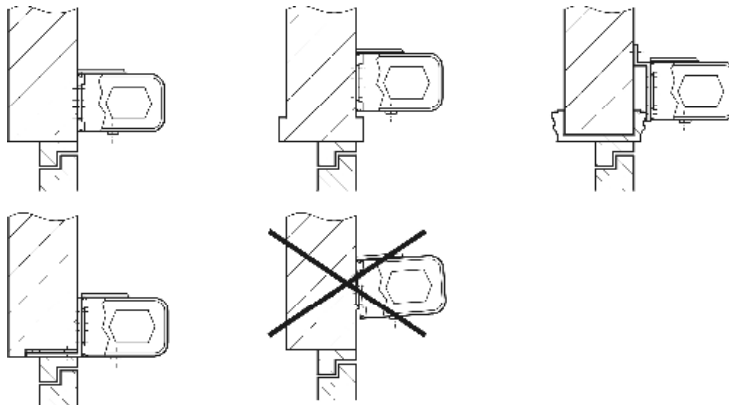

11.2 Positioning the DFA and arm

- Mark the drilling positions on the template according to the type of installation, the mounting plate and the arm
- Fix the template to the corresponding position
- Drill the boreholes. After the first borehole the chassis can be used as template

11.3 Mechanical installation of the DFA



The casing must not be opened or disassembled due to the possibility of injuries caused by spring tensions being suddenly released.

- Dismount the power supply and gear drive unit of the operator
- Fix the mounting plate, place the cables in position and mount any flexible connections.

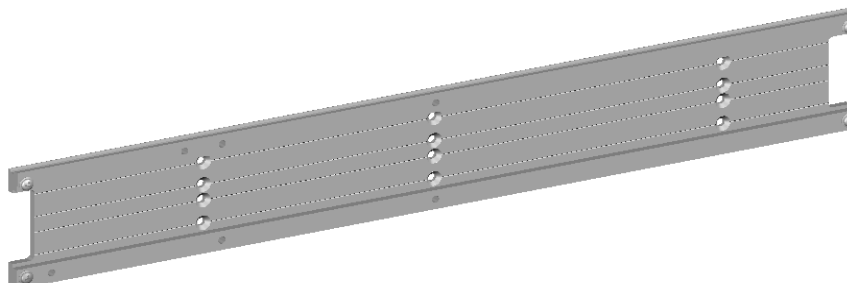

11 Installation and commissioning

- Assembly of the ATM operator module

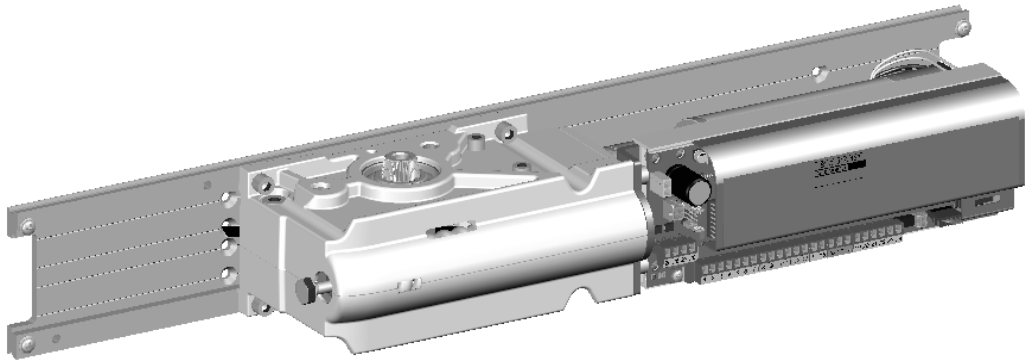

- Fix the NET mains supply and connect the connector cables to the STG controller.

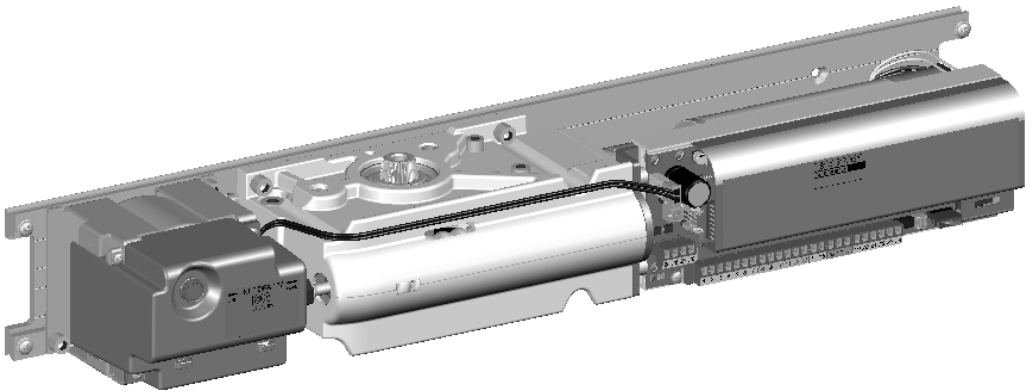

- Prepare the arms (refer to: *10 Adjustment of the arms*), fix the arms in correct position with regard to the DFA, screw the arms to the door leaves and adjust the angle (90°) of the arms to the door leaf

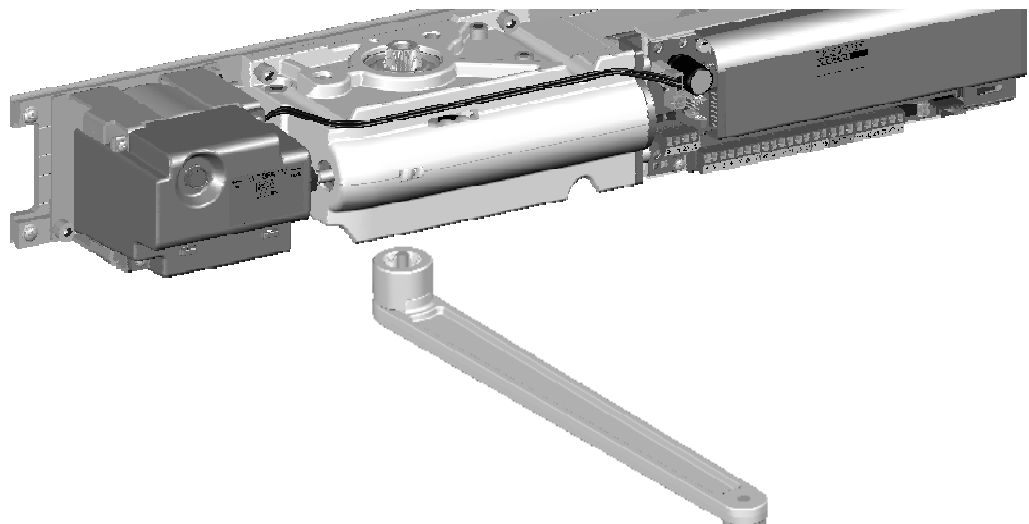

Installation

11.4 Adjustment of the initial spring tension (EN 4 to EN 6)

Depending on the width of the door leaves, the spring force must be adjusted corresponding to EN 1154 in the range of EN 4 to EN 6. The adjustment range can be taken from the table in chapter 3.1 based on the width of the door leaf. Wind loads, under/over-pressure and other environmental conditions must be taken into account during the adjustment.

The door operator is set to a minimal spring force on EN 4 in the factory. This is appropriate for door leaf widths from 950 to 1100 mm.

If the width of the door leaf is 1,100 mm, for example, an additional maximum permissible door leaf weight of approx. 160 kg can be selected.

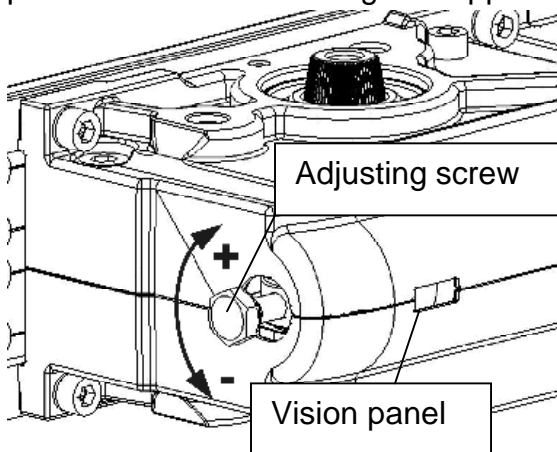

Turning the adjusting screw (SW13) clockwise increases the initial spring tension.

The white marking in the vision panel relates to the scale underneath.

- The correct setting of the initial spring tension is necessary for the proper opening of the door without the mains supply.
- **An unsuitable initial spring tension can cause malfunctions!**

11.5 Checking the mechanical functions

- Are the arms fixed at the correct angle to the door leaf? (See chapter 10 *Adjustment possibilities for the arm*)
- When moved by hand, does the door leaf move easily over its full swing?
- Does the operator damp the opening by spring force? If not, the slide switch position S1 on the motor print MOT must be changed.

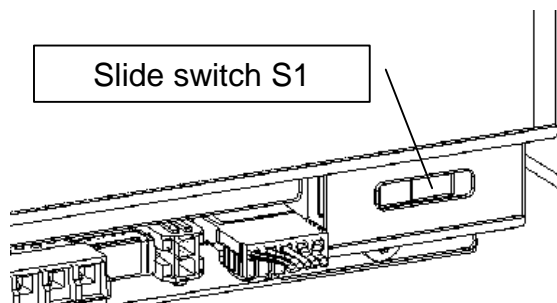

The switch position is set according to the direction of rotation of the arm while **closing**. If, for example, the arm moves away to the left when closing, the slide switch must be set to the left.

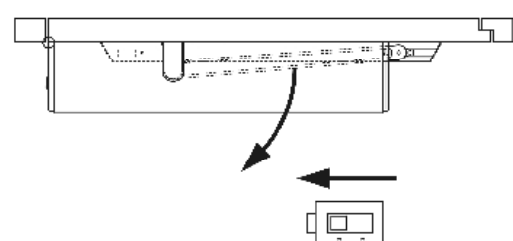
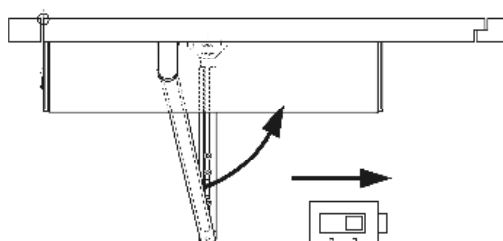

Installation

- Does the DFA work as mechanical door closer?
- With slide arms: Acceleration before definite closing visible?

11.6 Connecting the sensors, electrical door openers

- Connect the radar, the optical sensor-strips and the electric door openers (electrical door openers must have a suppressor diode) with the power switched off.

11.7 Preparation



Read and pay attention to safety instructions (chapter 2)!

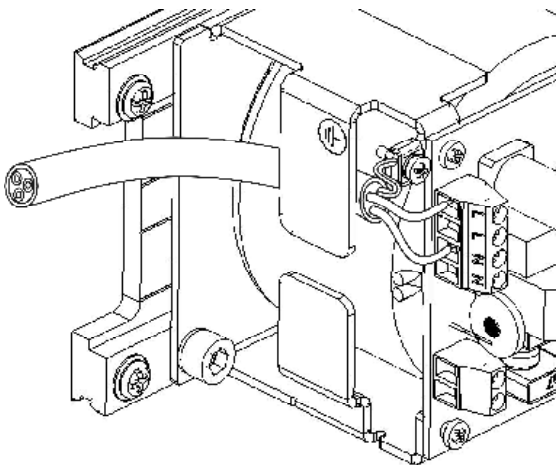

1. Interrupt the power supply with the main switch or power plug
2. **The power supply cable must be connected to the power supply DFA (feed the cable to the connectors complete with its sheath)**
3. Check the wiring according to general schematic diagram 127.108.904



The power supply must be fused with max. 10 A.

11.8 Checking the settings

1. Position the jumpers for the required function according to chapter 13, Operating Instructions
2. Check the external jumpers for auxiliary units that are not connected, such as EMERGENCY STOP, SIS, SIO



3. SIO / SIS (if present) must be connected and adjusted before the calibration run.

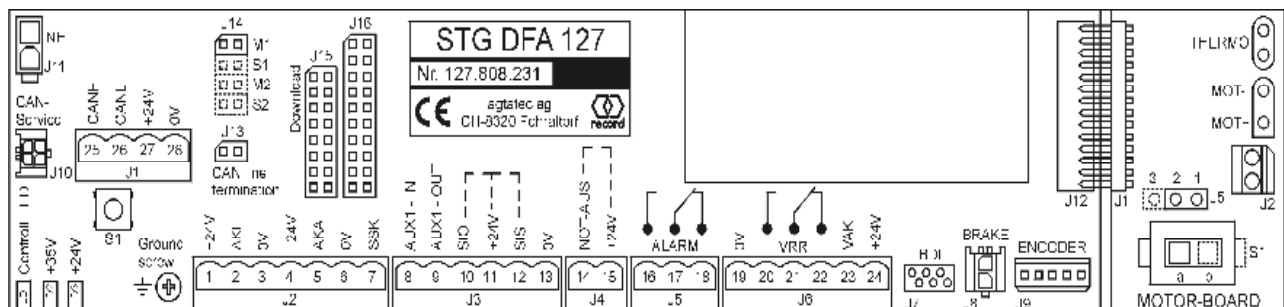

12 Commissioning

12.1 Commissioning

Legend:

- M** Master-operator
- S** Slave-operator
- MF** Multifunctional switch on controller
- FPC** record programming device (Flash-Programmer)

Operator	Instructions	Description
M+S	Operators are turned off	
M+S	Adjust initial spring tension	Procedure according to chapter 11.4 and table in chapter 3.1
M+S	Check that the switch for direction of rotation is adjusted correctly	Setting according to chapter 11.5 The arms <u>must not</u> be connected to the operator
M+S	Check that the CAN-connection has been made over the CAN-insulation	
M	Check that Jumper 13 is set to M1 on STG	HW detection for Master STG
S	Check that Jumper 13 is set to S1 on STG	HW detection for Slave STG
M	Switch operator to manual mode	With operation switch BDI
M+S	Turn on operators	
M+S	MF 8. light pulse	Load default parameters
M	MF 6. light pulse FPC 902: Master / Diagnostic / Door parameters	Separate the arm from the operator! Carry out the spring learning. Check the spring value and read-just if necessary.
M	FPC 902: Master / Parameter / Drive / Arms	Check the correct settings of type of arms
S	MF 6. light pulse FPC 902: Slave / Diagnostic / Door parameters	Separate the arm from the operator! Carry out the spring teaching. Check the spring value and read-just if necessary.
S	FPC 902: Slave / Parameter / Drive / Arms	Check the correct settings for the type of arm

Commissioning

M+S	Turn off the operator	
M+S	Mount arms	Approx. 6° initial tension
M+S	Check that the retarding effort while closing without mains supply is correct	
M+S	Turn on the operator	With Master/Slave-Installations turn on the Slave first.
M	Set the locking mechanism and door type	
M	Switch to manual mode	With operation switch BDI
M+S	Connect the sensor-bars SIO, SIS (if available)	These sensors should work properly, because they are adjusted during the calibration run.
M	MF 3. light pulse	Start the calibration run
S	MF 3. light pulse	Start the calibration run
M+S	Connect the sensors and actuators to AKI/AKA if present	
M+S	Final settings of the operators	



For Master / Slave- installations, also refer to chapter 16



The door must not be obstructed in any way during the calibration run.



In case of uncontrolled door motion, immediately disconnect the mains power supply by turning off the main switch or unplugging the mains power plug.

Commissioning

12.2 Checking the LEDs on the STG

Check LED 1...3 according to the table in chapter 13.

12.3 Checking the BDE functions and actuation devices

BDE position  **(permanently open)**

1. Door must open and remain open
2. Check the movement characteristics
3. Door cannot be moved by hand when open

BDE position  **(locked)**

1. Door must close
2. Check the movement characteristics
3. Check locking if present (see chapter 17 for status message for malfunction)
4. Pressing  a second time initiates the SSK opening
5. SSK must release (if present)
6. AKI and AKA must not operate

BDE position  **(one-way traffic)**

1. AKI and SSK must operate
2. AKA must not be triggered when the door is closed

12.4 Programming door speeds and hold-open times

The possibilities are described in chapter 13, “operating instructions”

12.5 Configuration of specific customer settings

The possibilities are described in chapter 15, “configurations”

All modifications must be entered on the configuration sheet (located in the operator)

Commissioning

12.6 Safety check

1. BDE position  (automatic mode)
2. Open door (e.g. with AKI)
3. Operate a safety device while closing. Door must re-open.
4. The same check must be performed with every safety device present.

12.7 Checking automatic reverse

1. Obstruct door while closing. The door must reverse. When the door next closes it moves at creep speed past the obstruction point.
2. Obstruct the door while opening. The door stops for hold-open time and closes. When the door next opens it moves at creep speed past the obstruction point.

12.8 Touch control (push to actuate)

See about the configuration in chapter 15. By pressing lightly on the door, a door-opening will be initiated.

12.9 Checking the functions of the DFA

- Check all the DFA functions
- Tighten the arm screw

12.10 Hand over to the client

- Instruct the client
- Hand over the operating manual
- RESET demonstration

13 Operating instructions

13.1 Controls on the STG 127

General:

The STG 127 operates with an active HIGH level, i.e. a +24 V level must be applied to activate a function. Safety inputs are activated during interruptions. The signal ground (0V) is connected to the protective earth.

Jumpers:

J14: Master / Slave
jumper at position M1 for master (factory setting)
jumper at position S1 for slave

J13: CAN line termination

LED's:

LD1: (red) Control LED for push-button operation (S1)

LD2: (green) +35V
Off for power failure

LD3: (green) +24V
Lights up if +24V present.
Caution: in the event of a power failure a processor reset takes place 1 second after this LED goes out.

Operating instructions

Key (S1):

This is a multifunctional key.

The selection of the function is carried out by the control LED according to the following table:

Release key while:	Function:
1 st light pulse on LD1	AKI
2 nd light pulse on LD1	
3 rd light pulse on LD1	Learn door parameters
4 th light pulse on LD1	Configuration mode on
5 th light pulse on LD1	
6 th light pulse on LD1 *	* Learn spring type
7 th light pulse on LD1	
8 th light pulse on LD1	Default parameter loading of door type (TT)
9 th light pulse on LD1 **	** Factory setting of programming and configuration
Press key for approx. 13 seconds	Hardware reset (new start of control)

* **Learn spring type must be carried out without connection to the door leaf!**
(Before initiating this function, the arms must be dismantled, i.e. the door leaf must not be connected to the operator!).

If a control unit is changed, this function must be initiated!

** In order to definitively carry out this function, a **Reset must be initiated within 9 seconds** (for example, with BDE-D, FPC 902, Test box). This can also take place on the DFA 127 via an EMERGENCY STOP.

Operating instructions

13.2 Functions of the BDE-D electronic controller (optional)

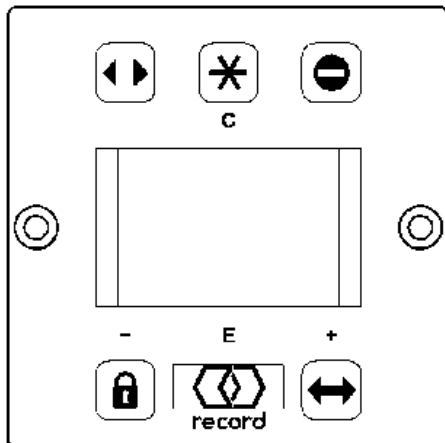

The BDE-D electronic controller is an easily operated input and output device for the control and adjustment of record door operators. Logically arranged pushbuttons allow intuitive operation and navigation through the operator-specific menu. The LCD with backlight shows data and information about the door status with symbols and text messages. Additional information can be found in the BDE-D manual (No. 903 108 983).

Automatic / AUTO

Normal function

Table of signals (X marks a release reaction)

	Closed	Opening	Open	Closing
AKI	x	x	x	x
AKA	x	x	x	x
SSK	x	x	x	x
SIO		x	x	x
SIS			x	x
TIPP	x			

One-way traffic / EXIT

In the one-way traffic mode people cannot enter the room from the outside but can leave it from the inside.

Table of signals (X marks a release reaction)

	Closed	Opening	Open	Closing
AKI	x	x	x	x
AKA*		x	x	x
SSK	x	x	x	x
SIO		x	x	x
SIS			x	x
TIPP				

* AKA is active as safety device while closing

Operating instructions

Manual operation / HAND

The door can be opened and closed by hand. The manual operation mode can be adjusted individually with 6 parameters. The description of the parameters is found with the parameters.

Open continuously/ OPEN

The door is opened and stays open.

Locked

The locking is activated in the Locked operation mode.

Table of signals (X marks a release reaction)

	Closed	Opening	Open	Closing
AKI		x	x	x
AKA		x	x	x
SSK	x	x	x	x
SIO		x	x	x
SIS			x	x
TIPP				

OFF

This operation mode can be used only in the USA. The operator is switched to manual operation (without configurations). An SSK opening is possible, but only under surveillance because some monitoring functions are disabled. Functions like parameter settings, Flash-update, ... continue to work.

Table to signals (X marks a release reaction)

	Closed	Opening	Open	closing
AKI				
AKA				
SSK	x	x	x	x
SIO				
SIS				
TIPP				
BODYG			x	x
RAILB			x	x

RESET

After pushing the  button for approx. 5 seconds, this status message on the display will read:

No
Reset Operator?
Yes

Push on the  button again to reset the operator.

14 Mech. control elements and indication

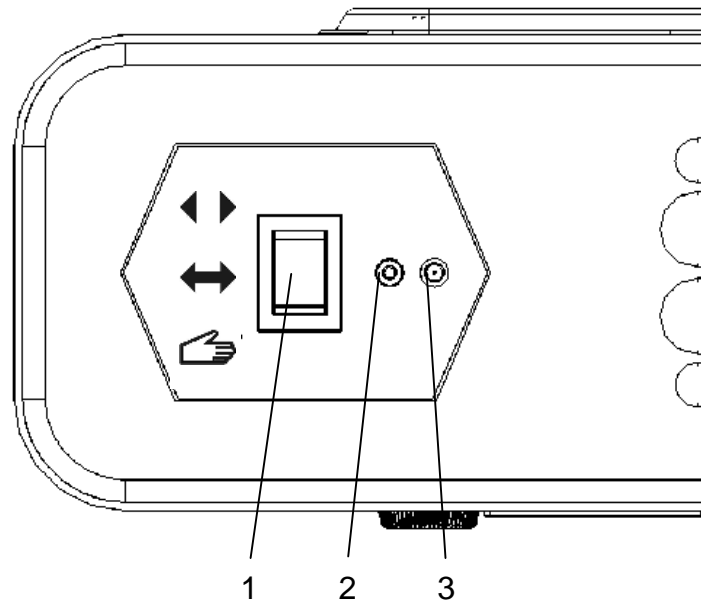

- 1 Mechanical BDI with 3 positions (control toggle switch)
- 2 Reset button
- 3 Status signal

Mechanical BDI (control toggle switch)

The following operational modes can be set up with the 3-position toggle switch on the side cover:

Manual operation :

In this operation mode, the DFA works as a normal door-closer. It can easily be opened manually, and then closes automatically. The connected actuating elements are inactivated.

Automatic :

The door opens and closes automatically, either through the activation of an actuating element or by pushing with activated touch control.

Continuously open :

The door opens and remains in the open position. If an obstacle is encountered while opening, the DFA will attempt to bring the door to the set open position for the next few seconds. If the obstacle is still present, the current position will be accepted as the continuously-open position.

Operating instructions

With the factory default setting, the mechanical BDI is always connected and active on a DFA 127. If an additional electronic BDE-D is connected, the operating mode will be set at the highest priority by a defined priority structure in the BDE.

The priority and the code shown in the following table apply to the operating mode, whereby BDE2 (S2) and BDE1 (S1) represent the two STG input terminals (à J7/1 + J7/2, Print BDE-M) for the mechanical BDE:

(L = interruption or 0V, H = +24V)

Mechanical BDI (toggle switch)		Electronic BDE-D	
BDE2 (S2)	BDE1 (S1)	Function	Priority (1=highest)
		locked	1
		one-way	2
L	H	continuously open	3
H	L	manual	4
L	L	automatic	5

The BDE-D indicates the current operating mode.

If an operating mode that has no current priority is set on the BDE-D, status message 62 is displayed.

Reset button

If this button is held down for approx. 5 sec. a re-start of the control is carried out (software reset). The LED lights up permanently after the reset.

Status signal

Remains off if no fault is present.

Blinks if a fault is present (see Status and Fault Signals / chapter 17)

Lights up continuously during a reset.

15 Configurations

15.1 Parameter Overview Factory settings: Basic operator (Full Power)

record parameter overview sheet DFA 127			Please <u>always</u> leave the parameter overview sheet in the operator even when the STG is replaced!						≥ V1.31	
Master or Slave			All parameter modifications must be marked as follows in the relevant box: Speedo: programmed value parameter value: X (mark)							
D = Value will reset after default parameter loading S1 = Slave 1 or Slave 2 M = Change in parameter only with multifunctional button on control unit (technical level)										
Parameter number			Parameter value (factory settings printed bold)							
D	S1	Description	M	1	2	3	4	5	6	
DRIVING CYCLE										
X		Closing speed			(Speedo)					
X		Opening speed			(Speedo)					
X		Acceleration	M		(Speedo) Different accelerations					
X		Latch check	M		(Speedo) Start latch check by closing					
TIME DELAY OPEN										
X		Time delay open			(Speedo)					
X		Time delay SSK			(Speedo)					
DRIVE										
X	X	Opening angle			(Speedo)					
X	X	Collision			(Speedo)					
	X	Brake	M	Without	Closing position	Opening position	Open/Clos pos.			
	X	Types of arms	M	Standard arm	Sliding pulling	Sliding pushing	Inheader			
		Invers	M	Disabled	Enabled					
	X	Spring type	M	Unknown	EN 4	EN 5	EN 6			
X		Limit open	M	Disabled	Enabled					
ENTRANCE SYSTEM										
		Fire alarm	M	Disabled	Enabled					
X	X	Control	M	Single control	Master control	Slave control				
X		Interlock type	M	Without interlock	Master-Slave (single leaf interlock control)	Master-Master (double leaves interlock control)				
		Door type	M	Basic operator	USA	USA Low Energy	EU Low Energy	UK	UK Low Energy	
MS 2-LEAVES										
X		Function AKA	M	Master+slave	Master only					
X		Overlap	M		(Speedo) 0 = No overlap					
X		Open sequence	M		(Speedo) 0 = Simultaneous opening					
X		Close sequence	M		(Speedo) 0 = Simultaneous closing					
MANUAL CONTROL										
X		During closing	M	Disabled	Enabled					
X		When locked	M	Disabled	Enabled					
X		When automatic	M	Disabled	Enabled					
X		Collision	M	Disabled	Enabled					
X		Support during closing	M	Disabled	Constant	Cumulative	Final bang	Slowly, cumulative	Slowly, final bang	
X		Active sensors	M	Disabled	SIS disabled	SIS enabled				
X		Closing speed	M		(Speedo)					
CONTROL PANEL										
X	X	Mech. panel	M	3 Pos. (AUTO) Manual; Automatic; Cont. open	4 Positions Automatic; Manual; Cont. open; Locked	3 Pos. (OFF-A) Automatic; OFF; Cont. open	3 Pos. (OFF-M) Manual; OFF; Cont. open	3 Pos. (Lock-A) Automatic; Locked; Cont. open	3 Pos. (Lock-M) Manual; Locked; Cont. open	
		BDE-D (submenu)								
		Language	M	Deutsch	Français	English	English US			
		Keyboard	M	Normal	OFF-Mode					
		Contrast BDE 1	M		(Speedo)					
		Contrast BDE 2	M		(Speedo)					
		Light time	M		(Speedo)					
LOCKING										
		Locking function	M	Normally locked	Always locked					
		Lock type	M	Standard	Locking bolt	Magnet	Pulse			
		VRR manually	M	Disabled	Enabled					
		Start delay	M		(Speedo)					
INPUT										
X		AUX1_IN	M	Disabled	BEA Bodyguard					
X		AKA_IN	M	AKA	Railbeam					
OUTPUT										
X		AUX1_OUT	M	Disabled	BEA Bodyguard	Test sensors				
MISCELLANEOUS										
X	X	Push to actuate	M	Disabled	Normal (motored)	Slow (motored)	HB with sensors			
Order number:			Client:							
Programming by end customer / changes			Date	Initials						



This parameter overview shows all possible settings. Depending on drive type and configuration the access is restricted.

Configuration

Configurations of the DFA 127 can only be made with the electronic BDE-D or the optional Testbox. If a toggle switch is connected, a BDE-D or Testbox must be connected briefly for the configuration.

Please always leave the configuration review sheet in the drive even when the STG is replaced!

15.2 Parameter Description

Parameter	Setting range	Factory default	Description
DRIVING CYCLE			
Closing speed	0 - 40 (5 - 20 s)	18	Slider control with 40 steps
Opening speed	0 - 40 (3 - 20 s)	36	Slider control with 40 steps
Acceleration	0 - 40 (40 = max.)	36	Influences the start-up behaviour while opening and closing
Latch check	0 - 40	0	Earlier slow-down while closing elongates the length of run with minimal possible closing speed in the area of the last 20° (e.g. safeguarding against shearing edge)
TIME DELAY OPEN			
Time delay open	0 - 40 (0 - 60 s)	2	Effective with AKA, AKI and push to actuate 0 - 20: Steps of 1 s 21 - 40: Steps of 2 s
Time delay SSK	0 - 40 (0 - 60 s)	4	Effective with SSK 0 - 20: Steps of 1 s 21 - 40: Steps of 2 s
DRIVE			
Opening angle	0 - 40	35	The opening angle is estimated during the calibration run and is equivalent to the value of 40
Collision	0 - 40	20	Influences the force for the reversing 0: weak 40: strong
Brake	Without	Without	No brake integrated or no brake wanted
	Closing position		Holding brake with closed door
	Opening position		Holding brake with open door
	Open/closed position		Holding brake with open and closed door

Configuration

Parameter	Setting range	Factory default	Description
Types of arms	Standard arm	Sliding pulling	Standard arm for pushing opening
	Sliding pulling		Sliding arm for pulling opening
	Sliding pushing		Sliding arm for pushing opening
	Inheader		Special application (for USA only)
Inverse	Disabled	Enabled	Opening of the door by spring tension in case of power failure.
	Enabled		
Spring type	Display only	EN 4	Springiness value is estimated during calibration run (MF 6. light pulse). Control with FPC 902: Spring type: EN 4: value from 35-41 EN 5: value from 42-59 EN 6: value from 60-89 Display <i>Unknown</i> , if the value could not be estimated or lies out of range.
Limit open	Disabled	Disabled	Enabled: The door is hold stronger in the open position.
	Enabled		
ENTRANCE SYSTEM			
Fire alarm	Disabled	Enabled	Enabled: specific adaptation for the requirement of the EN-norms for fire doors.
	Enabled		
Control	Single control	Single control	This setting is effected automatically under operating conditions. Simulation or Master/Slave-Control can be set with the FPC 902.
	Master control		
	Slave control		
Interlock type	Without interlock	Without interlock	Function not yet integrated
Door type	Basic operator	Basic operator	Frequently-used door types can be chosen for specific applications.
	USA		
	USA Low Energy		
	UK		
	UK Low Energy		

Configuration

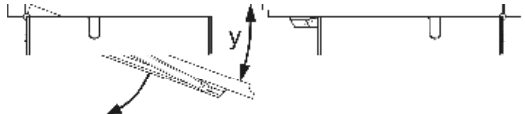
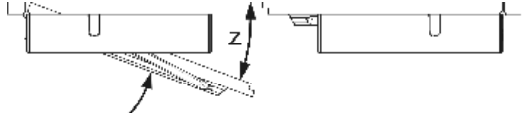
Parameter	Setting range	Factory default	Description
MASTER/SLAVE 2 DOOR LEAVES			
Function AKA	Master + Slave	Master + Slave	AKA is effective on both operators
	Master only		Entry AKA is only effective on the Master operator, AKI and SSK are effective on both operators. One-way mode not possible.
Overlap	0 - 40	5	<p>Only one door leaf moves in the pre-set overlap region.</p> <p>During the opening, the stationary leaf waits until the moving leaf has left the overlap region y.</p>  <p>During closing, the moving leaf waits until the stationary leaf has closed.</p> 
Open sequence	0 - 40	5	Delayed start-up of the stationary leaf
Close sequence	0 - 40	20	<p>Delayed closing of the moving leaf</p> <p><i>All modulators at 0 = synchronous activity.</i></p> <p><i>Opening or closing sequence on 40: The subsequent door leaf waits until the first leaf has entirely opened or closed. With this setting, the overlap has the highest priority.</i></p>

Configuration

Parameter	Setting range	Factory default	Description
MANUAL CONTROL			
During closing	Disabled	Disabled	Enabled: The door closes motor-guided only with spring tension.
	Enabled		
When locked	Disabled	Disabled	Enabled: When the door is in the <i>Locked</i> operation mode, it can be opened manually. The closing does not take place automatically. (<i>night watchman mode</i>).
	Enabled		
When automatic	Disabled	Disabled	Enabled: When the door is in the <i>Automatic</i> operation mode, it can be opened manually. The closing does not take place automatically.
	Enabled		
Collision	Disabled	Disabled	Enabled: If the door leaf during closing stands still longer than 1 s, it is reopened with motor force. Active only, if a motor forced opening is allowed, e.g. <i>Manual control/Active Sensors</i> .
	Enabled		
Support during closing	Disabled	Disabled	Constant: constant motor closing force during the last 10°.
	Constant		Increasing motor closing force if the closing is obstructed during the last 10°.
	Cumulative		Excursive increasing motor closing force during the last 2°.
	Final bang		Slow closing with increasing motor closing force, if the closing is obstructed during the last 10°.
	Slowly, cumulative		Decelerated closing with excursive increasing motor closing force during the last 2°.
	Slowly, final bang		
Active sensors	Disabled	Disabled	No sensor active
	SIS disabled		All sensors active (without SIS)
	SIS enabled		All sensors active (including SIS)
Closing speed	0 - 40	20	Slide control with 40 steps, setting the closing speed as it sees fit. Present locks must lock in place. This depends on the adjusted spring force.

Configuration

Parameter	Setting range	Factory default	Description
CONTROL PANEL			
Mechanical panel (BDE-M) ¹⁾	3-digit (AUTO)	3-digit (AUTO)	<i>Manual; Automatic; Cont. open</i> Function corresponds to the symbols on the three-step rocker switch BDI on the side cover of the DFA 127.
	4-digit		<i>Automatic; Manual; Con. open; Locked</i> Adequate setting for time switch entries (e.g. <i>SUR-V</i>). Only possible with optional BDI-M.
	3-digit * (OFF-A)		<i>Automatic; OFF; Cont. open</i>
	3-digit * (OFF-M)		<i>Manual; OFF; Cont. open</i>
	3-digit * (LOCK-A)		<i>Automatic; Locked; Cont. open</i>
	3-digit * (LOCK-M)		<i>Manual; Locked; Cont. open</i>
			* CAUTION: Function <u>does not</u> correspond to the symbols on the three-step rocker switch BDI on the side cover of the DFA 127.
BDE-D (<i>à</i> Submenu)			
Language	Deutsch	English	Language for the text output
	Français		
	English		
	English US		
Keyboard	Normal	Normal	Standard-Function (not for the USA)
	OFF-Mode		Special mode according to the description in chapter 13.2. The <i>Locked</i> mode is replaced by <i>OFF</i> .
Contrast BDE 1	0 - 40	0	Contrast setting for the BDE 1 display.
Contrast BDE 2	0 - 40	0	Contrast setting for the BDE 2 display.
Light time	0 - 40	0	Length of time for backlight: 0: No backlight 1 - 39: Corresponds to 1 - 39 s after pushing a key on the BDE-D 40: Continuous backlight
			<i>Changes to the setting of the BDE-D are only effective after a restart.</i>

Configuration

Parameter	Setting range	Factory default	Description
LOCKING			
Locking function	Normally locked	Normally locked	The VRR interlock is operated with the <i>Lock</i> button on the BDE-D or via the <i>Lock</i> position of the switch on the BDE-M.
	Always locked		The interlock VRR is permanently active and unlocks before opening with each connected actuator.
Lock type	Standard	Standard	For the standard electronic lock (e.g. eff-eff). The operator holds the door closed until the lock is unlocked. It remains actuated until the door is fully opened.
	Locking bolt		Suitable for motor-lock. The operator holds the door closed until the lock is unlocked. The power remains on until the door is closed again. <i>The VAK input waits a max. of 5 s for indication of the reverse signal input of the lock before the door opens.</i>
	Magnet		Analogous to bolt-function, but without holding closed.
	Pulse		The operator holds the door closed until the lock is unlocked. It remains actuated until the door is approx. 10° opened.
VRR manually	Disabled	Disabled	Enabled: All the actuators are disconnected if a signal is present on the VAK input from the reverse signal input of the lock . Approved for doors that are closed manually.
	Enabled		
Start delay	0 - 40 (0 - 8 s)	0	Application for motor locks without reverse signal on the input VAK. The opening is time-delayed.
INPUT			
AUX1_IN	Disabled	Disabled	Special function, currently for the USA only.
	BEA Bodyguard		
AUX2_IN	AKA	AKA	Special function, currently for the USA only.
	Railbeam		

Configuration

Parameter	Setting range	Factory default	Description
OUTPUT			
AUX1_OUT	Disabled	Disabled	Special function, currently for the USA only.
	BEA Bodyguard		
	Test sensors		For safety sensors with integrated test input.
MISCELLANEOUS			
Push to actuate	Disabled	Disabled	Normal: the operator reacts only on a short acceleration of the door leaf and not on slow movements caused by increasing pressure (e.g. wind).
	Normal (motored)		
	Slow (motored)		Reaction like above, but slow door opening
	Manually operated with active sensors		The door can be opened manually. Special function, currently for the USA only.

15.3 Different factory defaults for different door types

EU Low Energy

Parameter	Factory default	Parameter	Factory default
DRIVING CYCLE		MANUAL CONTROL	
Closing speed	10	During closing	Enabled
Opening speed	20	Collision	Enabled
Acceleration	15	Closing speed	10
DRIVE			
Collision	5		

Parametrierung

UK

Parameter	Factory default	Parameter	Factory default
MANUAL CONTROL			
When locked	Enabled		
When automatic	Enabled		

UK Low Energy

Parameter	Factory default	Parameter	Factory default
DRIVING CYCLE		MANUAL CONTROL	
Closing speed	10	During closing	Enabled
Opening speed	20	When locked	Enabled
Acceleration	15	When automatic	Enabled
DRIVE		Collision	Enabled
Collision	5	Closing speed	10

15.3 Special remarks

¹⁾ If the value **2** has been programmed and an external mechanical BDE (BDE-M) has been connected, the inputs (BDE1, BDE2) will be interpreted in a different manner. On the circuit board in the mounting set, BDI-M DFA 127 (127.808.232) is equipped with clamps that permit the external adjustment of the operation mode according to the table below.

Terminal connections on the circuit board in the mounting set:

Input/output on STG DFA 127	Clamps on STG DFA 127	Clamp marking on BDI-M
BDE 1	J7/1	1
BDE 2	J7/2	2
+ 24 V	J7/3	3



If using the circuit board on the side cover, only the RESET button and the Status signal remain in function!

Configurations

Function chart:

Mechanical BDE (external BDE)		
BDE2 / clamp 2	BDE1 / clamp 1	Function
L	L	locked
L	H	continuously open
H	H	manual
H	L	automatic

(L = interruption or 0 V, H = + 24 V)

Toggle switch BDI on the side cover or external			
BDE2 / Clamp 2	BDE1 / Clamp 1	Function if the external mech. BDE is <u>not</u> configured	Function if the external mech. BDE will be configured
L	H	continuously open	continuously open
H	L	manual	automatic
L	L	automatic	locked

List of parameters:



If no BDE-D is connected and the DFA 127 is connected to an electronic lock, the “Always locked” operation mode must be configured.

Menu: Locking / Locking function / Always locked



For the correct function of “Manual operation with active sensors” the function must be configured and the BDE-D or the rocker switch must be set on .

The door can be operated manually like a common door. For handi-capped people the door can be opened by a remote control.

Menu: Manual control / Active sensors / SIS disabled or SIS enabled

Do not activate manual control with supported closing!

Configurations



For Master/Slave operators, the input AKA can be configured so that only the Master door leaf (moving leaf) opens if there is a trigger!

Menu: MS 2-Leaves / Function AKA / Master only

Connection of a time switch for "locked" (SUR-V)

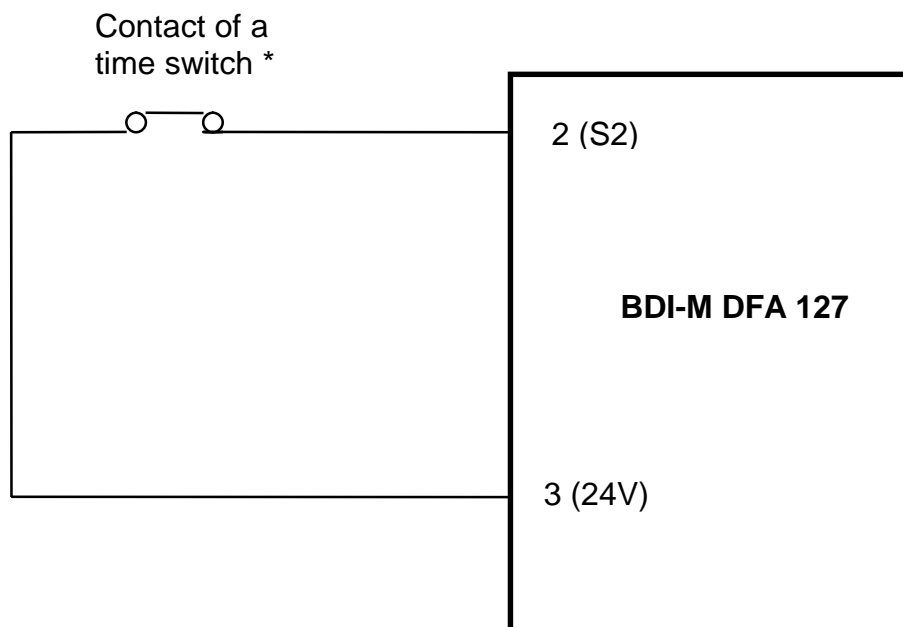

- | | |
|------------------|---|
| * Contact closed | = mode of operation according to the position of the operation switch |
| Contact open | = "Locked" mode of operation |



In combination with a BDE-D control unit, it is recommended to activate the control lock of the BDE-D (or).

Otherwise, the door can no longer be unlocked using an external mechanical BDE-M or external signals to the BDI-M circuit board after selection of the "Locked" operating mode if it has been locked in the meantime with the BDE-D!

16 Master / Slave Application

16.1 Use

The master / slave control allows the DFA 127 to perform sequential controls without the need for external supplementary devices. This master / slave control is used with double-leaf doors that require specific opening and closing sequences. A particular feature of the master / slave control of the record DFA 127 is that all the safety functions recognised by the DFA also function with double-leaf doors. This applies in particular to **reversing, obstacle recognition, and slow mode**. The two controls continuously communicate with one another via the intelligent interface between the master and the slave operator, so that any obstacle within the swing range of one door is always recognised by both drives.

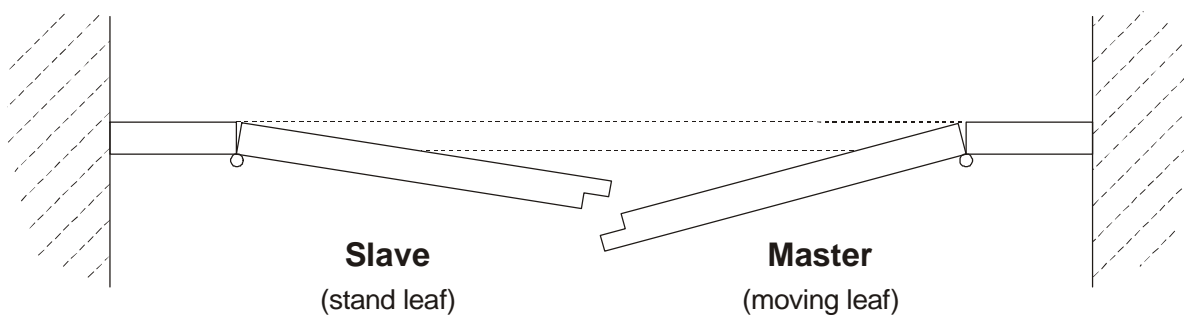

16.2 Functions

The functions of the master and the slave operators correspond basically to those of the standard DFA.

The following points are specifically mentioned:

Obstacle recognition: If one of the doors is obstructed during opening, only the obstructed door stops. In addition, during the next opening action, only this door will open in Slow-mode. The obstacle recognition for the two door leaves therefore functions independently for each door.

Reversing: Reversing, on the other hand, affects both door leaves, i.e., both doors reverse after one of them hits an obstacle. This avoids an obstacle in the swing range being hit by both door leaves.

BDE in Master / Slave installations: The operation of a master / slave installation can only take place from the toggle switch of the master operator. All operational modes are identical with those of a standard DFA. The switch position of the master affects both the master and the slave drive, i.e., the switch position of the slave drive is ignored.

Emergency switch: If a Master/Slave installation needs to have an emergency switch, a **2-pole** emergency switch must be used.
(refer to the Master/Slave wiring diagram in this manual)

Master / Slave Applications

16.3 Distinctive features

For master / slave installations, note that the commissioning differs from that of the standard DFA as follows:

- The operators of a master / slave installation must be connected together via the communication line and the CAN-isolator 127.808.247 (see master / slave circuit diagram in this manual).
- With the operators of a master / slave installation, the CAN bus terminating jumper J13 must be set to Master/Slave (see Master/Slave circuit diagram in this manual).
- The actuation devices must be connected to the Master. AKI, AKA and SSK will be ignored by the Slave.
- Safety actuation devices (SIO, SIS) that are mounted on both door leaves must be connected to the corresponding operator, i.e., the SIS on the Slave leaf must be connected to the Slave drive.
- Electric locks and possibly present locking contacts (VAK) must be connected to the corresponding operator, i.e., the electric lock on the Master leaf must be connected to the Master drive.
- Using jumper J14 on the STG 127, one operator is set as Master and the other as Slave. The operator of the active door leaf must always be selected as the Master (see Master/Slave circuit diagram in this manual).
- The current feed to both operators must either be switched on simultaneously, **or the Slave must be switched on first.**
- The calibration run is carried out individually for each operator. During the calibration run of the Slave, the Master opens as well, so that the Slave will not be obstructed.
- The opening and closing speed is the same for both operators, and the value is transmitted from the Master to the Slave. The opening time delay is also specified by the Master in the same way. If these values are to be modified, they must therefore be set on the Master operator; the Slave will take over the values immediately.
- The opening angle and automatic reverse, can be set separately at each operator. Refer to the parameter list for the settings.
- If one of the operators should fail, it is recommended that the second operator should also be disconnected from the power feed. Both operators can then be restarted normally as described above.
- Special function for overlap, opening and closing sequence
Menu: MS 2-leaves / overlap, open sequence and closing sequence / Parameter value 1 (Speedo)

17 Status and fault signals

Detail description of status indications

General:

In case of an irregularity, the display changes automatically from operation mode level to error display. The background colour changes between normal /inverse every 2 seconds. Several errors can be displayed (e.g. 1/2 means: Error No. 1 of total 2 errors).

Status notifications with a “W” are warnings. In this case, the error relay does not switch. The status can be reset by several means according to the detailed description.

A status can usually be deleted by pressing the  key for 5 seconds (= reset). This produces a restart in the control unit.

If the cause of the fault has not been eliminated, however, the status message will re-appear if the fault occurs again.

The following list gives the causes of faults in decreasing probability. The fault at the bottom of the list has the smallest probability of occurring in the STG.

- Status 3: AKI sensor active longer than 60 s**
Automatically reset if everything is in order, or by service fitter
- Status 5: AKA sensor active longer than 60 s**
Automatically reset if everything is in order, or by service fitter
- Status 6: Unlocking error**
Bolt possibly jammed
Reset by service fitter
- Status 9: “Opening” unsuccessful (after 4 collisions)**
Check the interlock / remove obstacle
Reset through service fitter
- Status 11: Faulty motor current**
Possibly faulty wiring in prefabricated cables
Replacement by service fitter
- Status 23: Slave control unit defective**
Replacement by service fitter
- Status 25: Slave connection (CAN) to Master interrupted**
Clear by service fitter
- Status 31: EMERGENCY STOP operated. Motor relay de-energises**
Reset by resetting the EMERGENCY STOP button
- Status 37: Motor current**
STG or ATE defective
Reset by service fitter

Status and fault signals

- Status 38: Overheat motor**
Manual control effective
Door leaves possibly too heavy, or too much friction
Reset by motor cooling down or by service fitter
- Status 39: Overload on + 24 V supply**
Too many external units possibly connected
Reset by service fitter
- Status 41: Motor – temperature sensor defective**
Motor possibly not connected
Sensor in motor possibly defective or cable break in sensor lead
Reset by service fitter
- Status 43: Incremental encoder fault**
Input cable possibly not connected or cable break in the lead
Motor possibly blocked
Reset by service fitter
- Status 45: Motor current – time product to high**
Motor relay de-energises
Manual control effective
Automatic reset by motor cooling or by service fitter
- Status 46: Control unit STG defective**
Includes the following individual faults:
EPROM, RAM, Watchdog, I_{max}, I_{maxT}, difference on SHE-EXT
Reset by service fitter
- Status 47: SIO sensor active longer than 60 s**
Automatically reset if in order, or by service fitter
- Status 50: CPU2 is defective**
Reset by service fitter
- Status 51: Software version**
Software version of Master and Slave do not correspond to each other. Software update by service fitter
- Status 52: No running parameter**
Start calibration run
- Status 53: Interruption motor**
Possibly no connection to motor
Reset by service fitter
- Status 54: Calibration run**
Reset automatically

Status and fault signals

- Status 59: SIS sensor active longer than 60 s**
Automatically reset if in order, or by service fitter
- Status 60: Parameter memory (EEPROM) defective**
Change control unit
Reset by service fitter
- Status 61: SSK active longer than 60 s**
Automatically reset if in order, or by service fitter
- Status 62: BDE has no priority**
Because a higher-level signal is present
Automatically reset on release of BDE-button
- Status 72: Slave connection**
Master has no connection to Slave operator
Reset by service fitter
- Status 88: Difference parameter**
The common parameters of M/S operators do not correspond to each other.
Reset by service fitter
- Status 89: Master connection**
Slave has no connection to master operator
Reset by service fitter
- Status 90: Railbeam active > 60 sec.**
Automatically reset if everything is in order, or by service fitter
- Status 91: Bodyguard active > 60 sec.**
Automatically reset if everything is in order, or by service fitter
- Status 92: STG relay defective**
Replacement by service fitter
- Status 93: Overvoltage 24 V (from 27V)**
- Status 94: Spring calibration**
Automatic reset
- Status 95: Error in sense of rotation**
- Status 96: EEPROM void**
- Status 99: Operator rotates**
The grease in the gear will be dispersed.
Automatic reset
- Status 105: Test brake**
Automatic reset

Status and fault signals

Status 106: Brake defective

Reset or reset by service fitter

Status 107: SIS defective

A safety sensor (with test input) in closing direction is defective.

Reset by service fitter

Status 108: SIO defective

A safety sensor (with test input) in opening direction is defective.

Reset by service fitter

Status 109: Factory settings

Status 110: No motor

No motor detection during initialisation (motor temperature sensor).

Check motor temperature sensor.

Reset or reset by service fitter



A status number with a "W" is a warning !!

18 Maintenance Instructions

The following points must be checked:

Base fixing	Is the DFA 127 securely fixed to the backing construction?
Chassis	Is the attachment still normal?
Door hinge	Can the door leaf be moved smoothly?
Arm	Has the fixing screw of the arm been firmly tightened?
Function	Does the movement of the door give reason for dissatisfaction?
Wiring	Are all the cables connected and have the clamping screws been firmly tightened? Are all connection assemblies to the motor in order?
Calibration run	Initiation of a new calibration run
Control unit	Check the function of all modes of operation
Actuating devices	Function test of motion sensors, push button, pull-switch etc.
Safety elements	Function test of safety cells on door leaves (SIO/SIS).
Safety functions	Examine the external connections (fire alarm / EMERGENCY STOP / SSK).
Electrical door lock	Function test of electrical door lock and monitoring (Input VAK; signal or switching contact).
Casing	Are the casing and the side cover plates properly installed?

19 Control references with new assembly

The following points must be checked:

Base fixing	Is the DFA 127 securely fixed to the backing construction?
Chassis	Is the attachment still normal?
Door hinge	Can the door leaf be moved smoothly?
Door leaf	Do the leaf weight and the leaf width correspond to the defaults in accordance with diagram in this manual?
Arm	Has the fixing screw of the arm been firmly tightened?
Function	Does the movement of the door give reason for dissatisfaction?
Electric supply	Is the outer sheathing of the supply cable intact up to the mains adaptor cover?
Wiring	Are all cables connected and have the clamping screws been firmly tightened? Are all the connection assemblies to the motor in order?
Control unit connection	Was the prescribed cable used and has it been installed correctly?
Configuration	Was the operator configured in accordance to the default? Was the configuration sheet filled out and placed under the operator's casing?
Calibration run	Has a calibration run been completed?
Control unit	Functional check of all operation modes
Actuating devices	Adjustment and functional test of motion sensors, push button, pull-switch, etc.
Safety elements	Adjustment and functional test of safety cells on door leaves (SIO/SIS)
Safety functions	Check external connections (fire alarm, EMERGENCY STOP, SSK)

Control references with new assembly

The following points must be checked:

Electrical door lock	Does the electrical door lock have enough free motion? Is the diode fitted over the door lock connection? Functional test of the electrical door lock and the monitoring (Input VAK; signal or switching contact).
Casing	Have the casing and the side cover plates been installed properly?
Logo	Is the record logo correctly attached?

20 Abbreviations

A	ABS	Absolute pulse generator	M	MF	Multifunctional switch
	AKA	Actuating-contact "outside"		MOT	Motor
	AKG	Actuating-contact „common“		MP	Principal assembly diagram
	AKI	Actuating-contact „inside“			
	AS	Master wiring diagram / Circuit diagram	N	NA	Emergency stop
	ASK	Terminals inside header		NET	Power supply unit
	ATE	Drive unit		NS	Main power switch
				NSA	Mains failure
B	BDE-D	Electronic control unit	R	RAD	Radar
	BDI	Control unit (rocker switch)			
	BDI-M	Circuit board for mechanical control unit	S	SI	Fuse
	BKL	control unit LED		SIO	Safety open
				SIS	Safety close
C	CAN-H	serial data interface		SSK	Key operated contract control unit
	CAN-L	serial data interface		STG	control pc board
	CPU	central processing unit		STP	
D	DFA	Automatic swing door operator	T	TOE	door locking
				TOW	door opening width
				TOZ	door open time delay
E	EPROM	program memory	U	μP	Microprocessor
	ES	Electrical circuit diagram			
F	FV	Manufacturing regulation	V	VAK	locking contact
				VL	wiring list
G	GTR	Gearing		VMA	Instructions for wiring and assembly
H	HS	Main switch 2-pole		VRR	locking
I	IKG	Encoder			
L	LED	Light Emitting Diode			
	LD	Light Emitting Diode			
	LS	Cable plan			

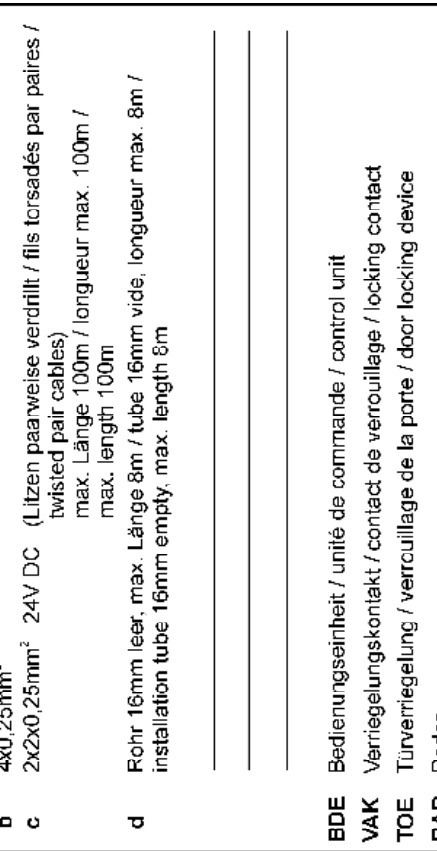
<p>Netz 230V 50 / 60Hz Sicherung 10A Anschlusswert 400W</p>	<p>Réseau 230V 50 / 60Hz Fusible 10A Puissance 400W</p>	<p>Electric mains 230V 50 / 60 cycles Fuse 10A Power rating 400W</p>
		
<p>Wichtiger Hinweis! Die Anlage soll während der Nacht NIE durch einen Generalschalter vom Netz getrennt werden.</p> <p>Ne pas débrancher le système du réseau pendant la nuit.</p> <p>Important notice! The installation is not intended to be disconnected from the mains at night.</p>		
<p>* Lieferung bauseits gemäss behördlicher Vorschrift A fournir par ailleurs selon spécification officielle To be furnished by others according to official regulation</p>		
<p>Auftrags-/Commande-/ Order-Nr/No: _____ Baustelle/ Chantier Site _____</p>		
<p>Nicht zutreffendes streichen! Positions non utilisées a biffer! Cancel unnecessary items!</p> <p>a 3x1,5mm² 230V AC (Ph+0+E) (L+N+E) b 4x0,25mm² c 2X2x0,25mm² 24V DC (Litzen paarweise verdreht / fils torsadés par paires / twisted pair cables) max. Länge 100mm / longueur max. 100mm max. length 100mm d Rohr 16mm leer, max. Länge 8m / tube 16mm vide, longueur max. 8m / installation tube 16mm empty, max. length 8m</p>		
<p>BDE Bedienungseinheit / unité de commande / control unit VAK Verriegelungskontakt / contact de verrouillage / locking contact TOE Türverriegelung / verrouillage de la porte / door locking device RAD Radar NA Notaus-Taster 2-polig / interrupteur de secours à 2phases / emergency stop button 2-pole HS Hauptschalter 2-polig / interrupteur principal à 2phases / main switch 2-pole</p>		
<p>Leitungsschema Schéma de câblage Cable layout</p> <p>Messstab: %</p> <p>Seite 1 von 2 / Page 1 de 2 / Sheet 1 of 2</p> <p>127.109.569 A</p>		

<p>Netz 230V 50 / 60Hz Sicherung 10A Anschlusswert 400W</p>	<p>Réseau 230V 50 / 60Hz Fusible 10A Puissance 400W</p>	<p>Electric mains 230V 50 / 60 cycles Fuse 10A Power rating 400W</p>
<p>auf beide Antriebe sur les deux mécanismes on both operators</p>		
<p>Wichtiger Hinweis! Die Anlage soll während der Nacht NIE durch einen Generalschalter vom Netz getrennt werden.</p> <p>Ne pas débrancher le système du réseau pendant la nuit.</p> <p>Important notice! The installation is not intended to be disconnected from the mains at night.</p>		
<p>★ Lieferung bauteils gemäss behördlicher Vorschrift A fournir par ailleurs selon spécification officielle To be furnished by others according to official regulation</p> <p>Auftrags-/Commande-/ Order-Nr/No: _____ Baustelle Chantier Site _____</p>		
<p>Messstab: % Seite 2 von 2 / Page 2 de 2 / Sheet 2 of 2</p>		
<p>Leitungsschema Schéma de câblage Cable layout</p> <p>DF A 127</p> <p>agtatec ag CH-8320 Fehraltorf</p> <p>127.109.569 A</p>		
<p>Bereiche für Kabelaustritte zones pour sorties des câbles areas for cable outlets</p> <p>Mitte Band Centre de la peinture Centre of door hinge</p>		
<p>Nicht zutreffendes streichen! Positions non utilisées a biffer! Cancel unnecessary items!</p> <p>a 3x1,5mm² 230V AC (Ph+0+E) (L+N+E) b 4x0,25mm² c 2x2x0,25mm² 24V DC (Litzen paarweise verdreht / fils torsadés par paires / twisted pair cables) max. Länge 100m / longueur max. 100m / max. length 100m d Rohr 16mm leer, max. Länge 8m / tube 16mm vide, longueur max. 8m / installation tube 16mm empty, max. length 8m</p> <p>BDE Bedienungseinheit / unité de commande / control unit VAK Verriegelungskontakt / contact de verrouillage / locking contact TOE Türverriegelung / verrouillage de la porte / door locking device RAD Radar NA Notaus-Taster 2-polig / interrupteur de secours à 2phases / emergency stop button 2-pole HS Hauptschalter 2-polig / interrupteur principal à 2phases / main switch 2-pole</p>		

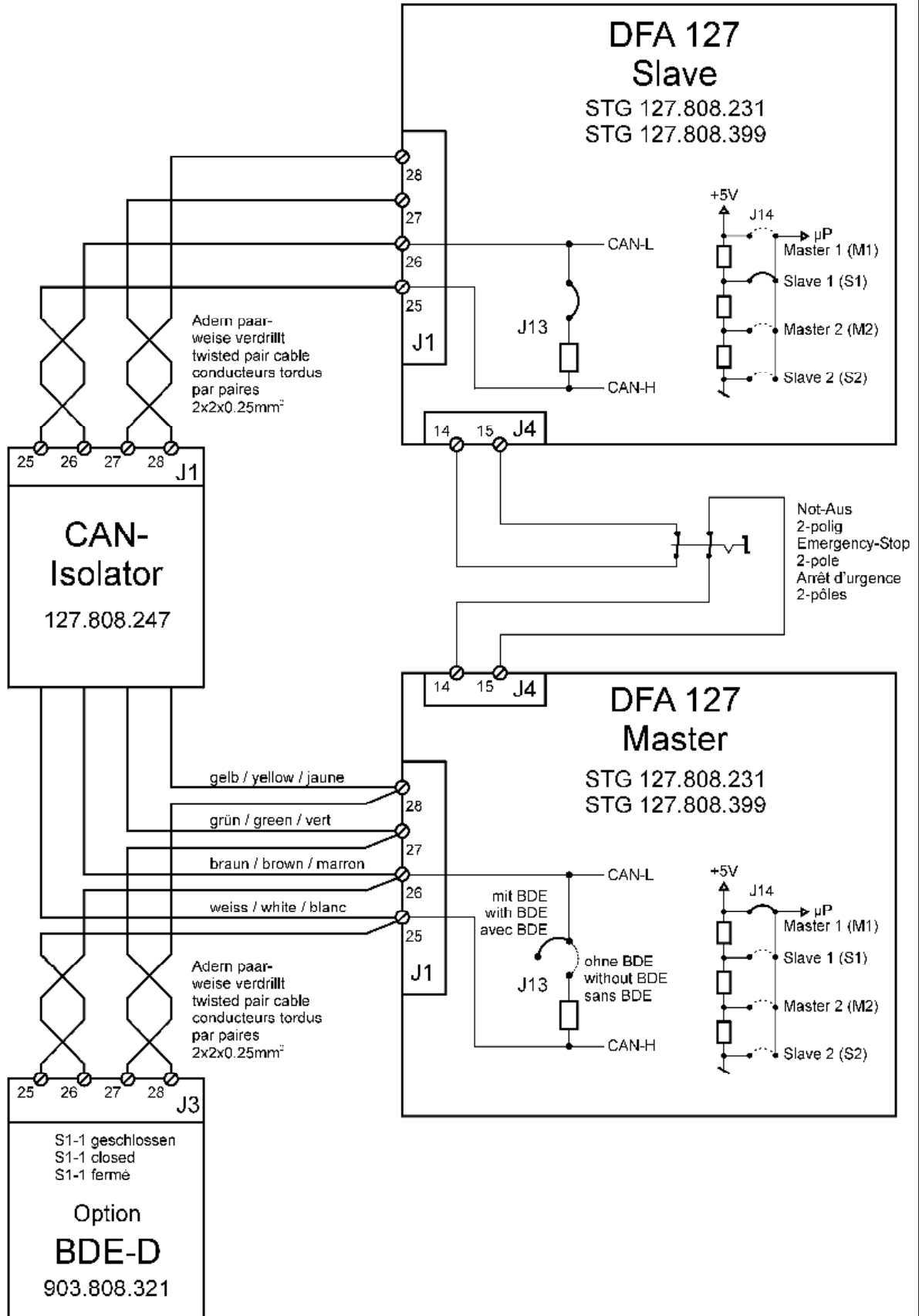

agtatec ag
CH-8320 Fehraltorf



Gezeichnet	km	01.12.06	Seite 1 von 1 / Sheet 1 of 1 / Page 1 de 1
Gepüft	bu	01.12.06	
Freigegeben	km	01.12.06	

127.109.570 A

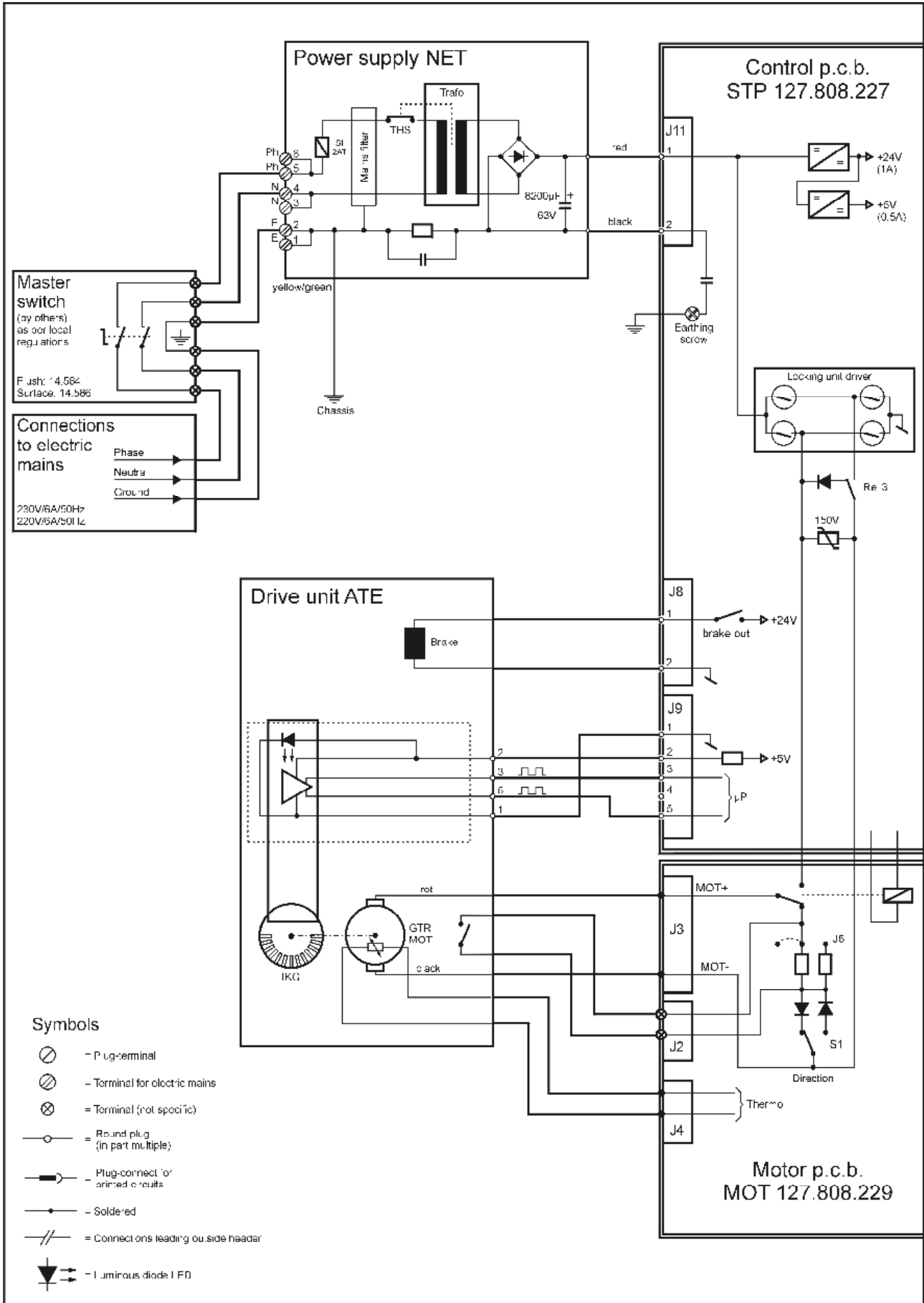

agtatec ag
CH-8320 Fehraltorf



Gezeichnet	km	11.07.2005
Geprüft	sh	27.03.2006
Freigegeben	km	27.03.2006

Sheet 1 of 2

127.108.904 D

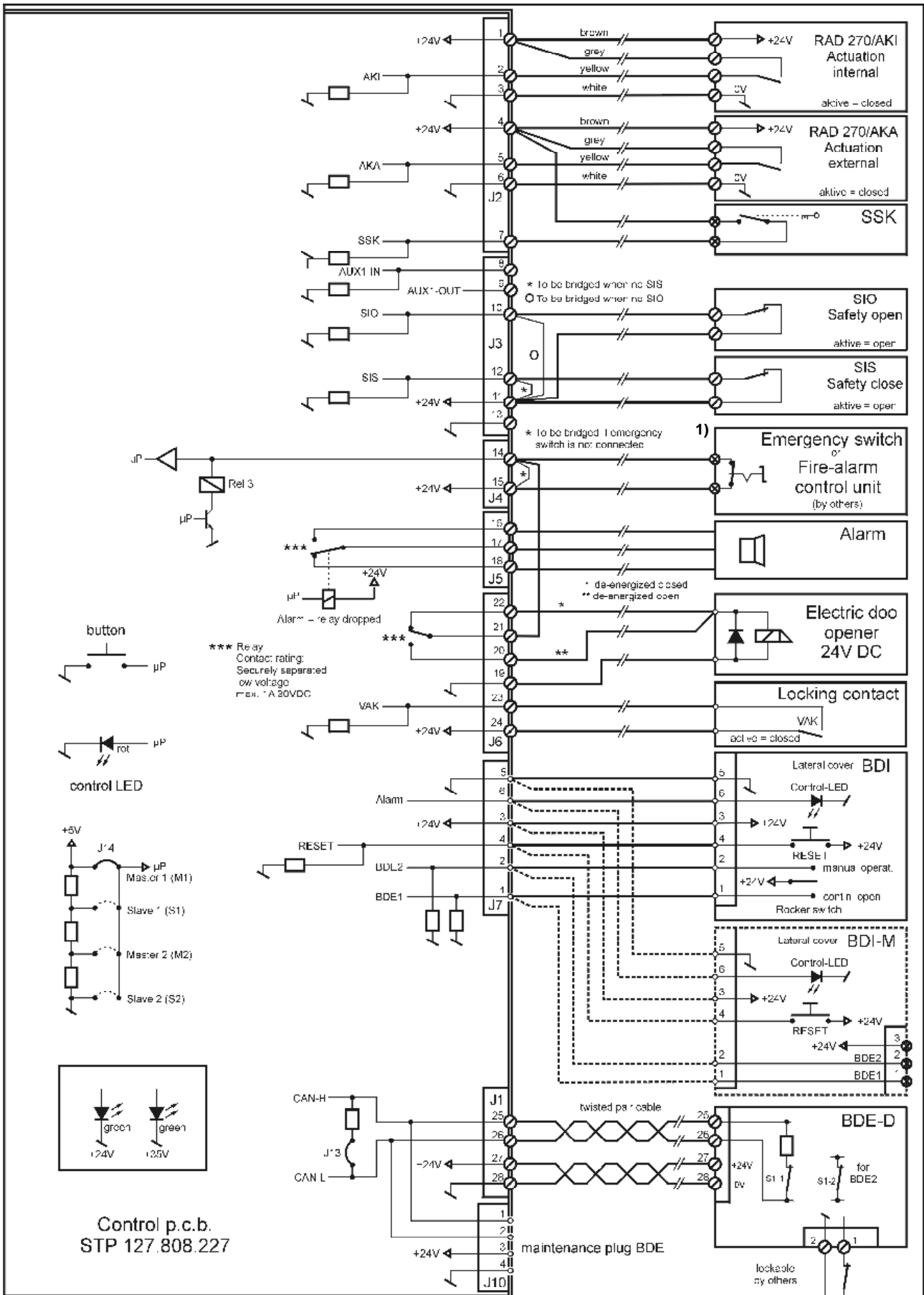

agtatec ag
CH-8320 Fehraltorf



Gezeichnet	km	11.07.2005
Geprüft	sh	27.03.2006
Freigegeben	km	27.03.2006

Sheet 2 of 2
127.108.904 D

1) Master / Slave installation: connect on both operators

Austria

record Türautomation
Helmut Heinz Bunzl Ges.m.b.H.
Zwingenstrasse 17
A-2380 Perchtoldsdorf
Phone +43 1 865 88 75
Fax +43 1 865 88 75 14

Denmark

record BMT A/S
Hovedstensvej 33
DK-2650 Hvidovre
Phone + 45 36 78 23 00
Fax + 45 36 77 16 28

France

record portes automatiques SA
ZAC-6, rue de l'Orme Saint Germain
F-91165 Champlan Cedex
Phone + 33 1 69 79 31 10
Fax + 33 1 69 79 31 29

Germany

record Türautomation GmbH
Dieselstrasse 7
D-42389 Wuppertal
Phone + 49 202 60 90 10
Fax + 49 202 60 90 111

Great Britain

record UK ltd
Smith Avenue – Garrion Business Park
Wishaw – North Lanarkshire – ML2 ORY
Phone + 44 1698 376411
Fax + 44 1698 376422

Hungary

record ajtó kft
Leshegy ut 8
H-2310 Szigetszentmiklós
Phone + 36 24 51 53 90
Fax + 36 24 51 53 92

Netherlands

Automatische deuren record B.V.
Cardanuslaan 30
NL-6865 HK Doorwerth
Phone + 31 26 33 99 777
Fax + 31 26 33 99 770

Poland

record drzwi automatyczne Sp.zo.o.
Nowa 23 Street
Stara Iwiczna
PL-05-500 Piaseczno, Stara Iwiczna
Phone + 48 22 73 77 100
Fax + 48 22 737 70 08

Spain

record Elemat S.A.
c/Francesc Vila, 20 Pol. Ind Can Magi
Apartado de Correos 185
E-08173 San Cugat del Valles
Phone + 34 93 674 26 50
Fax + 34 93 675 49 21

Switzerland (Headquarters)

record Türautomation AG
Allmendstrasse 24
CH-8320 Fehraltorf
Phone + 41 44 954 91 91
Fax + 41 44 954 92 00

